

FREQUENCY INVERTER

E2000

0,4kW – 400kW (IP20)

*Safety instructions Installation
& operating manual*

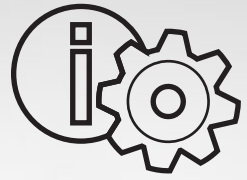

EURa[®]
DRIVES

| www.euradrives.eu |

ENGLISH

E2000_Rev.02 -EN- SOFT Rev. 5.09
© 2017 EURA Drives GmbH

INDEX

PAGE

1) Common installation- and safety rules for series E2000+ inverters	1
2) Product data / product power range	11
3) Inverter mounting	16
4) Electrical connection of E2000+ Inverters	17
5) Control-board – hardware and I/O channel configuration	24
6) Operating panel	31
7) Inverter parameter setting	33
8) Parameter group 100: Basic parameter	34
9) Parameter group 200: Inverter control	40
10) Parameter group 300: Digital I/O configuration	45
11) Parameter group 400: Analogue I/O channel configuration	49
12) Parameter group 500: Fixed-frequency, automatic cycling frequencies	53
13) Parameter group 600: DC-Bake control / Aux. functions	54
14) Parameter group 700: Error handling and protection functions	57
15) Parameter group 800: Autotuning – Motor data programming	61
16) Parameter group 900: RS485 Hardware and interface parameters	63
17) Parameter group A00: PID controller parameter	64
18) Parameter group C00: Speed / Torque control	68
19) Diagnostic functions	70

Rev. 02-EN-2016-06-KPP
Software revision: 5.09

1) Common installation- and safety rules for EURA DRIVES inverters, series E2000+

IMPORTANT!!

This instruction manual explains rules for correct installation and safe operation of frequency inverters, series E2000+ (denominated inverter, or drive in the following guidance). It is mandatory to follow exactly, what reported in this instruction manual.

This instruction manual must be read and fully understood before any action of installation or placing in operation of the inverter.

Anybody, who operates the inverter, or the machine, equipped with inverter, must have access to this operation manual, and must become familiar with drives technology, especially regarding safety and warning issues

All instructions in this manual must be observed, to:

Guarantee safety for humans and machinery
Allow safe function and reliable operation
Permit approvals and certifications
Keep manufacturers warranty in force

Following pictograms are used in this instruction manual:

DANGER-WARNING-CAUTION

ATTENTION: Life or health of the user are endangered or substantial damage to property may occur.



ATTENTION – OBSERVE

Measures, necessary for safe and trouble-free operation



Common:

DANGER



Frequency inverters operate with voltages, hazardous to humans

Depending on inverters protection degree (IP class) and mounting conditions, life parts may be accessible.

During heavy duty operation, and especially in case of malfunction, parts/surfaces of inverters or accessory may reach dangerous temperatures, which may result in personnel injury.

Inadmissible removal of covers or other parts of the inverter, improper use, and not qualified mounting or operation may result in high risk for personnel injury and/or machinery damage

DANGER



All activity for mounting, cabling, placing into operation and operation of the inverter must be done exclusively by proper educated and trained people.

The standards IEC 364 and/or CENELEC HD384, DIN VDE 0100 and all other national safety standards are to observe.

Trained people has specific professional training, knowledge of all relevant standards and safety rules and experience in application of electrical/electronic drive systems.

These professionals are in condition to judge assigned duties, and resulting risks.

Specified application of frequency inverters

DANGER



The inverters, reported in this manual are components of electrical/electronic drive systems and determinate for integration in machines and plants only.

The E2000+ inverter serves exclusively for the control and regulation of three phase motors (asynchronous / synchronous motors)

The connection of loads, other than above listed, may result in damage of the machinery, destruction of the inverter or connected equipment, and serious risk of personnel injury.

Observe specific standards and rules

DANGER



It is not allowed, to place in operation the plant, before the compliance with all standards of the machinery safety regulation (89/392/EWG) and the EMC rules (89/336/EWG) has been checked

Inverters are conformal with low voltage directive (73/231/EWG). Harmonized standards EN50178 (VDE160) and EN60439-1 (VDE0660, T. 500) are applied.

EURA DRIVES E2000+ is a product with limited availability (in sense of IEC 61800-3). Frequency inverters may create high frequency noise, in case the operator is responsible for proper countermeasures.

Handling, transportation and storage

DANGER



Inverter components may become damaged and insulating distances may be reduced, as a result of improper transportation, handling or storage of the drive.

In this case, the inverter does not anymore comply with product specific standards and rules, and it is not allowed to place it into operation.

Therefore it is mandatory, to check the inverter for mechanical integrity, before installation and operation.

The inverter may contain components, sensitive to electrostatic discharge. Therefore avoid, touch components inside the drive.

It is recommended to store the inverter, using the original box. If inverters are stored or out of use for more then one year, DC capacitors may lose their capacity. Please contact the inverter manufacturer for reformatting procedure

Installation of the inverter

DANGER



Frequency inverters must be installed in a proper cabinet.

Only fixed installation is permitted.

Follow all effective standards and rules for correct grounding!!

All minimum distances to other inverters or equipment in the cabinet are to respect. Minimum distances are reported later on this manual.

Allow adequate air circulating, especially, in case of vertical mounting, one on top of the other.

Use proper shielded cables, for inverter control signals and feed back signals

Intrusion of dust, liquids, water, steam and aggressive gases must be excluded

Attention on adequate heat exchange of the cabinet

Use of the inverter in explosion risky area is not allowed

Electrical wiring of frequency inverters

DANGER HAZARDOUS CAPACITOR CHARGE

The entire plant must be disconnected from power, crosschecked for loss of voltage and locked before starting any work



The discharge time of the internal DC-LINK capacitors may take up to 5 minutes, it is not allowed to open the enclosures or to do any maintenance work during discharge cycle!!

LVD – DOUBLE INSULATON



All connection terminals for control and feed-back are single insulated in sense of EN50178.

In case of connection to external equipment with double insulation, the user has to provide proper arrangement, to guarantee double insulation in sense of EN50178 for the whole system

GROUNDING



E2000+ inverters are designed for steady state installation, using fixed wiring. It is not allowed, to use power plug or similar mobile connection.

Depending on different EMC filter arrangements, the leakage current to ground may exceed 3,5 mA. Therefore it is recommended to use earth connection wiring, with minimum section of 10mm² (copper) or use double wiring (in sense of EN50178)

All grounding connections must be as short as possible, all leading to one common central point (star arrangement).



Long motor leads

A motor cable length, exceeding **30m**, may result in over-voltage spikes on the motor side. These peaks may damage the internal insulation of the motor.

The use of motor chokes, sinus filter or dV/dt limiting filters may prevent from risk of motor damage.

Generally it is recommended, to use inverter duty motors
In case of any doubt, please contact the manufacturer

All output filter components must have inverter manufactures approval

1) Common installation rules and safety information regarding EURA E2000+ inverters



Insulation testing

In case of insulation testing of the whole network, it is recommended to disconnect the inverter and all optionally mounted filter components. Some components, used inside the inverter may impact measurement accuracy, or may become destroyed

All EURA inverters have to pass the insulation test, according to EN15178, during the final test procedure on the production line.



Potential equalization

If components with no galvanic insulation are used and connected to the inverter, proper measures are necessary, to guarantee potential equalization.

**DANGER OF FIRE
BURNS**



Braking resistors

All kinetic energy of the system converts to heat, during braking cycle. This energy dissipates in the braking resistor.

Improper dimensioning of the braking resistor or insufficient heat exchange may result in high risk of fire

Also over-voltage on the input power supply may lead to high risk of fire

Therefore all braking resistor must have two thermistors, series connected, which contacts open in case of over-temperature, disconnecting the whole power supply, on inverter input terminals

Braking resistors surface may become very hot, even during normal operation. Therefore it is necessary to mount the resistor in a safe location, using proper protecting cages.

**IMPACT ON
DIFFERENTIAL
CURRENT
BREAKERS**



Differential current breaker (FI)

The use of frequency inverters may delay or even inhibit the trigger of differential current breakers.

For life protection, all plant with inverters must have following:

Input wiring protection: Fuses or automatic over-current breaker (Dimensioning: see tables).

Differential current protection: "All-sensitive" protectors (breaker), minimum requirement type „B“ , mounted on all inverter power lines.

It is not permitted to connect other equipment on inverter power lines.

For single phase inverters (230V class) the use of differential current breaker type "A" or "F" is allowed.

The trigger current of the differential current breaker depends on the operating frequency, motor type, PWM frequency and the length of the motor cable

It is recommended, to use differential current breaker with 300 mA threshold (for industrial environment).

Basic rules for reliable and safe operation

- Proper dimensioning of the system (motor, inverter, mechanical elements).
- Check for correct inverters rated voltage, consider tolerances too
- Review all inverter and motor cabling, including correct terminal tightening torque (torque values: see table).
- Use proper cable for all control wiring, separate control cable from power cable, min. 15 cm distance. Use shielded cable for all control connections, exceeding 1 meter
- Twist wires to braking resistors or use shielded cables
- Shielded cables are recommended for motor connection too, especially with distances, exceeding 30 meters.
- Avoid earth loops, all earth connections should have large contact areas, all leading to one central grounding point (star connected)

**IMPORTANT FOR
SAVE INVERTER
OPERATION**

One separate circuit breaker is recommended for each inverter – allowing separate switch off of single inverters.

CHECK FOR PROPER INVERTER PROGRAMMING

Improper programming of the inverter may result in unpredictable behavior of the system and subsequent high risk of damage and/or personnel injury.

The inverter may be enabled for multiple automatic restart attempts in case of fault – delayed restart is possible.

Unpredictable systems reactions may become the result of internal inverter defects.

The inverter may ignore commands, speed, STOP instructions, or signals originated from external components.

The braking function of the inverter may fail.

Depending on the application, external safety components, working independently from the inverter, are required, to guarantee the safety of the whole system



Inverter protection-functions

Although the inverter is equipped with intelligent protections functions, the repetitive triggering of those functions may result in inverter damage.

The inverter is protected against output short circuit and earth fault, each displayed by a specific code on the display.

Repetitive earth faults and short circuits may damage the power stage of the inverter.

The motor must be fixed connected, in case, where interruption of the motor line is required (for safety reason), the circuit should open/close with inverter in STOP condition only (final stage disabled).

It is recommended, to keep the inverter powered on at all time, if for application reason repetitive power on cycling is required, it should not exceed one cycles every 5 minutes – otherwise contact the manufacturer.





Power-grid specification:

The inverter is build for symmetric three phase power supply systems, with voltage phase to earth/neutral not exceeding 300V. A transformer can be used for adaptation to higher voltages. For single phase inverters the maximum input voltage is 240V +15%, 400V class three phase inverters can work up to 460V +15%. Contact the inverter manufacturer, before connecting to unbalanced, floating, or unsymmetrical power systems.



Power supply – short circuit capability

Input chokes ($U_k=4\%$) are recommended to connect the inverter on a power grid with high short circuit capability, this especially for continuous full load operation. If the power supply capability exceeds by 20 times the inverter power, the use of chokes is mandatory.

Measurements on inverter input and output:

Current and voltage may have no sinus shaped waveform on inverters input/output side. If improper testing instruments are used, the result may become inaccurate, or in worst case, the inverter and/or the test instrument may become destroyed. On input side, the current waveform is composed by fundamental and harmonics, while on output side the voltage waveform is PWM modulated. The used instruments must be able to handle the various signal waveforms. For simple measurements, a high quality moving iron instrument could be suitable.



The inverter manufacturer must be contacted in case of any question, regarding this safety/instruction manual, or if some parts have not been fully understood.



Please ask before installing or placing on operation the system.

This is mandatory, to avoid any risk for machinery damage and/or personnel injury.

EMC: Basics and recommendations for installation

The E2000+ series inverters are electrical devices, designed for installation in industrial area. E2000+ inverters are not designed to work stand alone, these inverters are considered as part of a complex system, for this reason, no separate EMC marking is applied on the inverter. The machine builder / system integrator is obligated to prove the compliance with actual EMC standards for the whole system.

Normally, the inverter integrated EMC filters are sufficient, to meet the actual EMC limits (this has been confirmed by measurements, performed by independent body).

Inverters E2000+ are designed for use in "second environment", (in sense of EN61800-3). This means installation in industrial area, where power supply is done via separate transformer.

Fore installation in "first environment" (residential area – public low voltage power grid), additional filter components may become necessary, to meet EMC rules.

EMC - adequate installation

Mounting in metal cabinet, if possible, the cabinet should be divided into power and control area, using metal shielding barrier, or similar

Connect all metal parts, grounding cables, cable shields on one central point, using the blank mounting plate as contact area.

Use 10mm² cables for potential equalization, "star" connected on one central point. Please consider, that inverters and filters may have more than 3,5 mA leakage current, therefore use proper earth/ground conductors:

Grounding conductor min. 10 mm² (copper)
Grounding connection with separate monitoring system, which disconnects automatically in case of fault.
Dual grounding, using separate cable and terminals.

Use shielded cables, wherever possible, with copper mesh, common cable steel protection is not working as shield.

Connect shields on large blank areas with potential equalization bars. Use special cable glands, with integrated contact brushes.

It is not allowed to extend cable shield, using single wire.

Mount all external filter components as close as possible to the noise source (inverter) – get perfect contact, mounting directly on the blank cabinet plate.

Keep all wiring as short as possible, separate different networks, min. 15 cm distance. Different networks are: power supply, motor cable (incl. brake resistor), low voltage control wiring (control signals, feed back, data line).

Twist all unshielded cables

Unused wires in cables should be connected to ground

Inverters with UL mark: Additional information

Following information are valid for inverters, designed for use in countries, which require UL approval. All information below must be available to all who are responsible for commercialization, installation and place in operation.

UL Standards

The UL/cUL mark applies to products in the United States and Canada and it means that UL has performed product testing and evaluation and determined that their stringent standards for product safety have been met. For a product to receive UL certification, all components inside that product must also receive UL certification.



UL Standards Compliance

This drive has been tested in accordance with UL standard UL508C, File No. E363934 and complies with UL requirements. To ensure continued compliance when using this drive in combination with other equipment, meet the following conditions:

- 1) Do not install the drive to an area greater than pollution severity 2 (UL standard)
- 2) Installation and operating instructions shall be provided with each device.

The following markings shall appear in one of the following locations: shipped separately with the device; on a separable, self-adhesive permanent label that is shipped with the device; or anywhere on the device itself.

- a) Designation markings for each wiring diagram;
- b) Markings for proper wiring connections.
- c) "Maximum Surrounding Air Temperature 40°C." or equivalent;
- d) "Solid State motor overload protection reacts when reaches 150% of FLA" or equivalent;
- e) "Install device in pollution degree 2 environment." or equivalent;
- f) For Models of Frame Size (E2000-0007T3UBR;E2000-0011T3 UBR;E2000-0015T3 UBR;E2000-0022T3UBR): "Suitable For Use On A Circuit Capable Of Delivering Not More Than 5,000 rms Symmetrical Amperes, 480 Volts Maximum When Protected By made by COOPER BUSSMANN L L C Class T Fuse: JJS-15." or equivalent.
For Models of Frame Size (E2000-0030T3UBR;E2000-0037T3UBR;E2000-0040T3UBR): "Suitable For Use On A Circuit Capable Of Delivering Not More Than 5,000 rms Symmetrical Amperes, 480 Volts Maximum When Protected By made by COOPER BUSSMANN L L C Class T Fuse: JJS-25." or equivalent.
For Models of Frame Size (E2000-0055T3UBR;E2000-0075T3UBR): "Suitable For Use On A Circuit Capable Of Delivering Not More Than 5,000 rms Symmetrical Amperes, 480 Volts Maximum When Protected By made by COOPER BUSSMANN L L C Class T Fuse: JJS-35." or equivalent.
- g) "Integral solid state short circuit protection does not provide branch circuit protection. Branch circuit protection must be provided in accordance with the National Electrical Code and any additional local codes" or the equivalent;
- h) "CAUTION – Risk of Electric Shock" should be provided, followed by instructions to discharge the Bus Capacitor or indicating the time required (5 minutes) for Bus Capacitor to discharge to a level below 50 Vdc;
- i) "Drives have no provision for motor over temperature protection" or equivalent;
- j) For used in Canada only: "TRANSIENT SURGE SUPPRESSION SHALL BE INSTALLED ON THE LINE SIDE OF THIS EQUIPMENT AND SHALL BE RATED ___480_ V (PHASE TO GROUND), 480 V (PHASE TO PHASE), SUITABLE FOR OVERVOLTAGE CATEGORY _III_, AND SHALL PROVIDE PROTECTION FOR A RATED IMPULSE WITHSTAND VOLTAGE PEAK OF _6 kV" or equivalent.

Field Wiring Terminal Markings – Wiring terminals shall be marked to indicate the proper connections for power supply and load, or a wiring diagram coded to the terminal marking shall be securely attached to the device:

- a. "Use 60/75°C CU wire" or equivalent;
- b. Required wire torque, type and range listed: see chapter 4) *Empfohlene Leitungsquerschnitte – Sicherungen Leistungsklemmen*

Grounding – The wire connector intended for ground connection for field installed equipment, shall be clearly identified such as being marked "G", "GRD", "Ground", "Grounding", or equivalent or with the grounding symbol (IEC 417, Symbol 5019).

Tightening torque and wire section for field grounding wiring are marked adjacent to the terminal or on the **EMV: Grundlagen und** wire section for field grounding wiring are marked adjacent to the terminal or on the wiring diagram.

2) Product data / product power range

Product naming convention

E2000 – 0007 S2

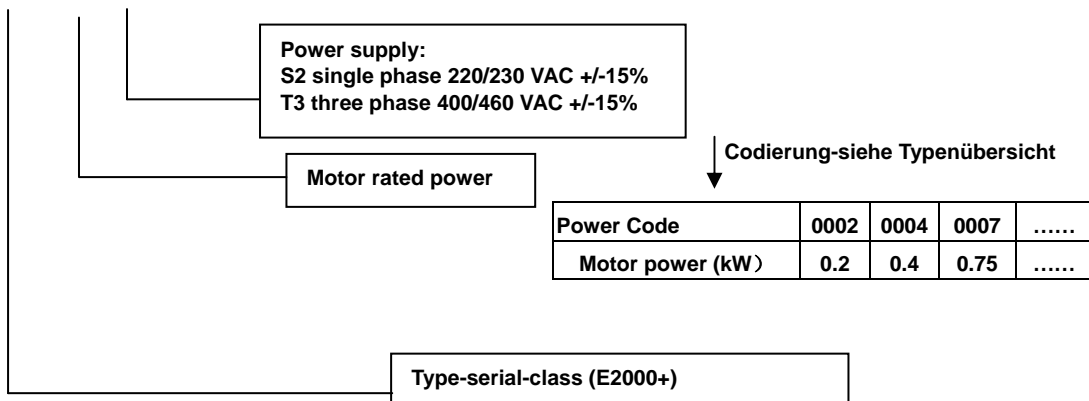

Options identifier

D F1 Y K B R

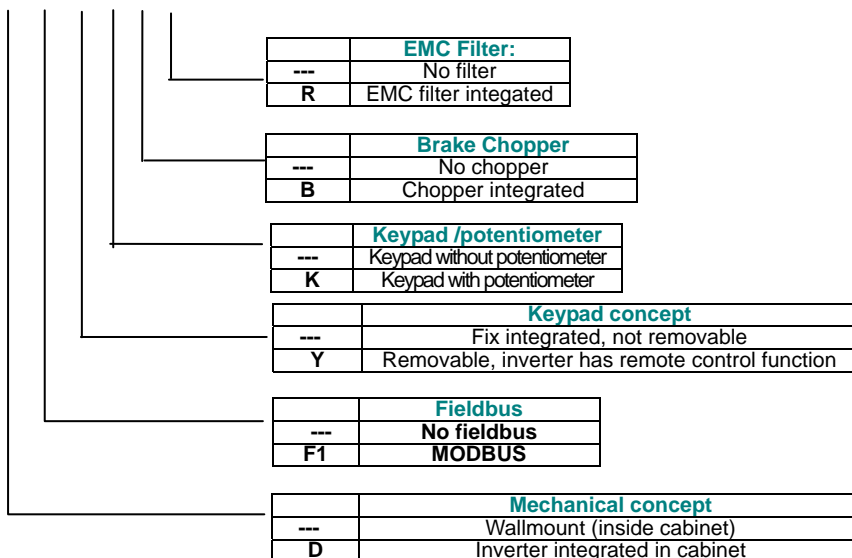

Nameplate

The adjacent picture shows a typical nameplate of an series E2000+, three phase, 400V 2,2 kW inverter, 6,5A rated current, including following options: F2 (MODBUS), B (Brake-chopper) R (integrated EMC-Filter)



2) Product data – product power range

2) Product data – product power range

Mechanical construction

There are two different basic concepts:

Inverter with power range from 0,2 to 22 kW: POLYCARBONATE enclosure, build on a constructional base (heatsink) with the keypad integrated on the cover (not removable) – framesize E1 – E6

Inverter with power range from 30 to 400 kW: Steel panel, power and control terminals inside, with the keypad integrated in the cover and removable - framesize C3 – C6

Appearance of an E2000+ Size E2 inverter



2) Product data – product power range

Appearance of an E2000+ Size C3 inverter



2) Product data – product power range

Technical data - inverter series E2000+

Power supply	Rated voltage	3-phase 380...460V +/- 15% - 1phase 230V +/- 15%
	Input frequency	44...67 Hz
	EMC filter	Integrated for 2. environment (up to 90 kW)
Output	Output voltage	0.....U-input
	Output frequency	0.....650 Hz
	Resolution of output frequency	0,01 Hz
	Overload capability	150% - 60 sec. / 10 Min
Control mode	PWM control-modes	V/Hz - Mode SENSORLESS VECTOR (SLV) – Speed / torque control Permanentmagnet Synchronus Motor PMM control
	PWM frequency	0,8.....16 kHz
	V/Hz characteristic	Linear, quadratic, and user-programmable curve – Voltage setpoint
	Starting torque	150% rated torque at 0,5 Hz (in SLV mode)
	Torque boost	Automatic / manual
	Motor data input	Manual input / intelligent AUTOTUNING function
	Speed range	1:100 in SLV mode
	Speed precision	+/- 0,5% (SLV)
	Torque precision	+/- 5% (SLV)
	DC-Brake	Freq. threshold, duration and intensity programmable – DC injection
	Brake chopper	Integrated chopper transistor (Brake resistors – see product table)
Display	7 Segment LED display -4- digit	For programming and visualization of different operating parameters
I/O Channels, control functions	Inverter control - Start/Stop	To configure: terminals / operation panel / serial link
	Digital control inputs	8 (6) digital inputs (HIGH/LOW configurable), pulse input
	Speed / torque reference signal	Potentiometer (on operating panel / Extern), analogue input (terminals), operating panel keys, pulse input, serial link
	Reference analogue channels	2 Analogue channels 0...10V, -10V/+10V, 0...(4)20 mA (with programmable offset, gain – to concatenate mathematically each other)
	Analogue outputs	2 analogue output channels, both programmable in gain, different functions to assign (0...10V, 0..20 mA)
	Digital outputs	2 digital outputs (different functions to assign)
	Relays output	1 switchover contact 5 A 230 V (programmable for different functions)
	Interface	Serial link (MODBUS – ASCII/RTU)
	Special function - control options	Jog mode, 12V / 50 mA auxiliary power supply on terminals
		PI-control / Pump control, Master/Slave control Fixed frequency control, programmable cycling frequency sequence "Catch on the fly function", AUTORESET/RESTART function
Protection functions, incl. fault memory	Electrical protection functions	Overvoltage, Undervoltage
		Overcurrent, Overload, Motor-Overload, Output-short
		Phaseloss, Motor-Phase imbalance
Thermal protection functions	Heatsink overtemperature – Motor overtemperature (PTC/KLIXON), Motor I ² t	
Optionals	Operating panel	Remote keypad / programming tool
	Brake resistors	High power resistors for heavy duty operation
	Filter / chokes	PFC chokes – dv/dt limiting output filter - sinusfilter
	Parameter copy stick	USB Stick with parameter duplication function – USB/RS485 converter
	PC-Link Software (via MODBUS)	Special tool for programming, control and diagnostic (parameter set memory)
Environmental conditions	Protection	IP20 – IP21 (optional)
	Operating temperature	-10.....+50 °C
	Humidity	Max. 90 % not condensing, no corrosion
	Elavation	1000 m - 1% derating / 100m above
Vibration	Max. 0,5 g	
Power range	SLV	0,2.....400 kW
	V/Hz	0,2.....400 kW
Standards	EMC	EN61800-3(2004)
	Safety	EN61800-5-1 2003

2) Product data – product power range

Power range – framesize

Inverter 230V								
Model	Rated power / current	Input current	Framesize	Enclosure	Weight (kg)	Dimension (WxHxD - mm)	Brake chopper	Min. brake resistance value
E2000-0004 S2B	0,4 kW - 2,5A	5A	E1	POLYCARB.	1,4	80x140x135	INTEGRIRERT	80 Ohm/200W
E2000-0007 S2B	0,75 kW - 4,5A	9A			1,5			
E2000-0015 S2B	1,5 kW - 7A	15A	E2		2,0	106x180x150		
E2000-0022 S2B	2,2 kW - 10A	22A			2,1			

Inverter 400V								
Model	Rated power / current	Input current RMS	Framesize	Enclosure	Weight (kg)	Dimension (WxHxD - mm)	Brake chopper	Min. brake resistance value
E2000-0007 T3	0,75 kW - 2 A	2,4A	E2	POLYCARBONATE	2,0	106x180x150	INTEGRATED	150 Ohm/200W
E2000-0015 T3	1,5 kW - 4 A	4,6A			2,1			
E2000-0022 T3	2,2 kW - 6,5 A	7A			2,2			
E2000-0030 T3	3,0 kW - 7 A	9A	E3		2,5	106x180x170		
E2000-0040 T3	4,0 kW - 9 A	11A	E4		3,0	138x235x152		
E2000-0055 T3	5,5 kW - 12 A	16A			3,5			
E2000-0075 T3	7,5 kW - 17 A	20A	E5		4,5	156x265x170		
E2000-0110 T3	11 kW - 23 A	29A			4,8			
E2000-0150 T3	15 kW - 32 A	37A	E6		8,0	205x340x196		
E2000-0185 T3	18,5 kW - 38 A	45A			8,5			
E2000-0220 T3	22 kW - 44 A	54A			9,0			
E2000-0300 T3	30 kW - 60 A	72A	C3		22,5	270x435x235		
E2000-0370 T3	37 kW - 75 A	85A	C4		24,0	315x480x235		
E2000-0450 T3	45 kW - 90 A	110A			24,5			
E2000-0550 T3	55 kW - 110 A	132A	C5		41,5	360x555x265		
E2000-0750 T3	75 kW - 150 A	180A		42,0				
E2000-0900 T3	90 kW - 180 A	220A	C6	56,0	410x650x300			
E2000-1100 T3	110 kW - 220 A	264A		56,5				
E2000-1320 T3	132 kW - 265 A	320A	C7	87	516x765x326			
E2000-1600 T3	160 kW - 320 A	384A	C8	123	560x910x342			
E2000-1800 T3	180 kW - 360 A	430A		124				
E2000-2000 T3	200 kW - 400 A	480A	C9	125	400x1310x385			
E2000-2200 T3	220 kW - 440 A	530A	CA	185	535x1340x380			
E2000-2500 T3	250 kW - 480 A	575A		186				
E2000-2800 T3	280 kW - 530 A	635A	CB0	225	600x1465x380			
E2000-3150 T3	315 kW - 580 A	700A		230				
E2000-3550 T3	355 kW - 640 A	765A		233				
E2000-4000 T3	400 kW - 690 A	830A	CB	234	600x1600x388			

Note: The indicated RMS input current is approximated for direct connection to a power grid, having a short circuit capability of 20kA – use adequate input chokes (5% choke) to reduce the RMS current

3) Inverter mounting

Please read all, what reported on chapter 1) *Common installation- and safety rules for EURA DRIVES inverters, series E2000+* before proceeding with inverter mounting, cabinet wiring, and putting into service the system.

Mounting in cabinet

Accordingly to the protection degree class (IP20/21), the inverter must be placed in a proper cabinet.

The inverter should be mounted vertically, using all available mounting holes.

Avoid mounting of more inverters in vertical array. If absolutely necessary, keep double mounting distances

The table below, shows the minimum mounting distances in vertical and horizontal direction

Sufficient heat exchange of the cabinet must be guaranteed, to keep all operating conditions within the specified limits.

Framesize	Mounting distance	
<30kw E1-E6	A≥150mm	B≥50mm
≥30kw C3-C6	A≥200mm	B≥75mm

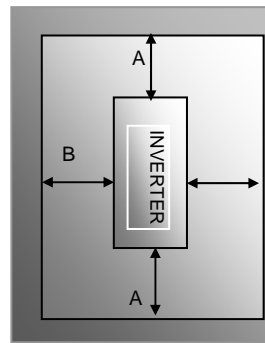

Distances for mounting in cabinet

Fans: All inverters out of the E2000+ series are forced ventilated. Specific parameters are used to set various fan operating modes: Always ON (F702=2), ON with inverter in running mode (F702=1), or temperature controlled (F702=0) (F703=Temp. threshold)

see 14) *Parameter group 700: Error handling and protection functions (F702-F703)*

Maintenance and service:

Provided that the inverter is working in respect of specified environmental conditions, provided that the inverter is used for proper application, and all instructions have been exactly followed for installation, putting in service and operation, the inverter does not need any specific maintenance.

4) Electrical connection of E2000+ Inverters

E2000+ inverters have separate terminals for power- and control-connection. Adequate cables are requested for wiring the inverter, all safety rules, reported in the first chapter of this manual are to observe.

Power terminals:

There are different arrangements for power terminals, depending on inverter size and number of input phases.

230V Singlephase inverter 0.2 – 0,75 kW – framesize E1

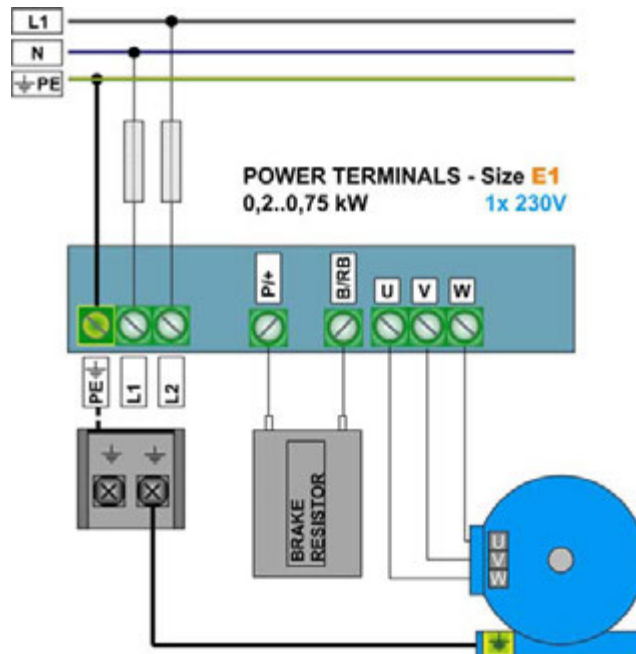

230 V Singlephase inverter 1,5 - 2,2 kW - framesize E2, E3

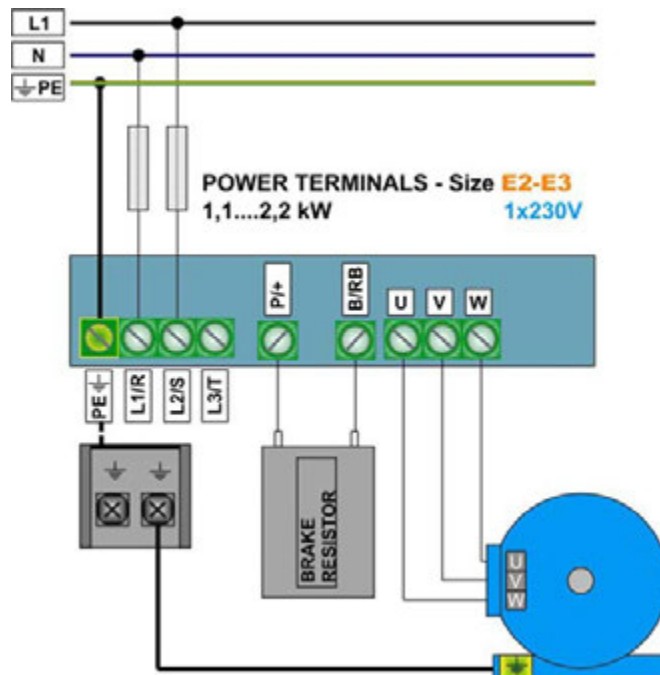

4) Electrical connections of E2000+ inverters

400V Threphase inverter 0.75 – 11 kW – framesize E2, E3, E4, E5

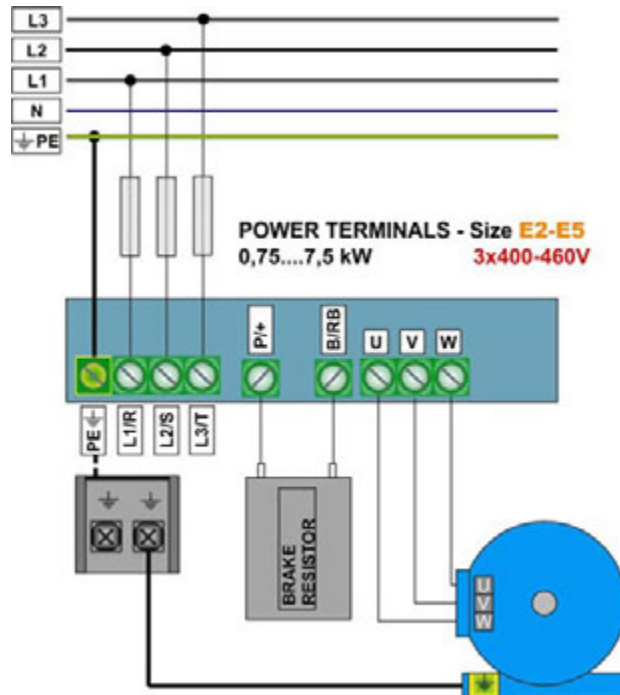

400V Threphase inverter 15 – 22 kW – framesize E6

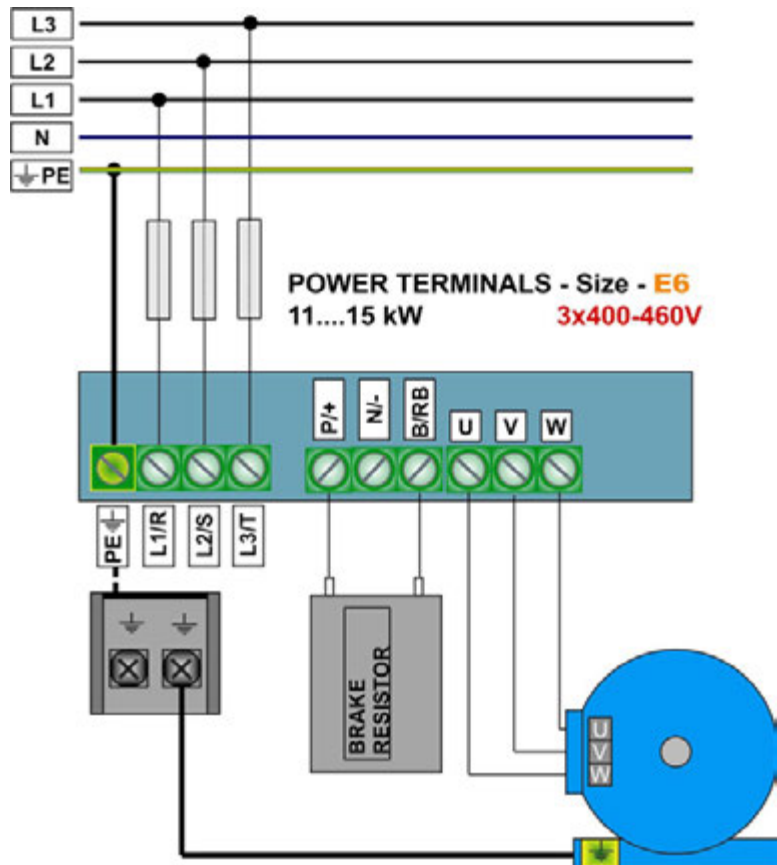

4) Electrical connections of E2000+ inverters

400V Threephase inverter - above 22 kW C3 – C6

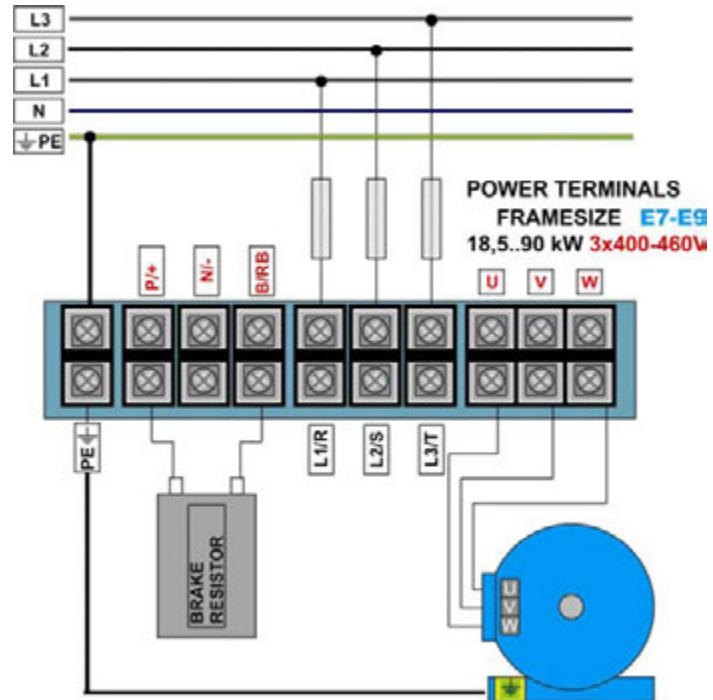

Brake resistor:

E2000+ inverters have built in chopper transistor as standard. An adequate brake resistor can be connected externally. The maximum length of the cable is 2mt, cross-section depends on the current through the resistor, calculated, considering the brake switch on voltage of 800V and the resistor value.

The minimum resistor value for single inverter power ranges is reported in table on chapter: 2) *Product overview / Product data* – **the value in the table is the absolute minimum value – resistors with up to three times higher resistance value are allowed.**

Right dimensioning of the resistor, especially in sense of continuous power and peak power depends on the application (inertia, speed, brake cycle rate).

EURADRIVES accessories program offers special resistors for all kind of application.



ATTENTION!! All stored dynamic energy of the system is converted in heat, during the brake process - heat, dissipated in the brake resistor. Overheating of the resistor, risk of burning and fire may be the consequence of improper dimensioning, wrong parameter setting, inverter fault or power supply over-voltage.

**It is necessary to provide suitable electrical and mechanical protection of the brake resistor
The rules in chapter 1) *Common installation and safety rules* are to observe.**

EURADRIVES does not take any responsibility for any damage or risk, if improper brake resistors are used.

Recommended cable cross sections, fuses, terminal tightening torque

Inverter model	Input current	Cable cross section (mm ² AWG) terminal tightening torque	Input fuses		
			IEC 60269 gG (A)	UL-Klasse T (A)	Busmann-Typ
	A	mm² / AWG / lbs/inch			
E2000-0007 T3	2,4	2,5 / AWG14 /10	10A	10A	JJS10
E2000-0015 T3	4,6				
E2000-0022 T3	7				
E2000-0030 T3	9				
E2000-0040 T3	11	2,5 / AWG12 /10,5	16A	15A	JJS15
E2000-0055 T3	16	4 / AWG10 /19	25A	20A	JJS20
E2000-0075 T3	20			30A	JJS30
E2000-0110 T3	29			6 AWG8 /30,4	35A
E2000-0150 T3	37	10 AWG6 /30,4	50A	40A	JJS40
E2000-0185 T3	45	16		50A	JJS50
E2000-0220 T3	54	16	63A	60A	JJS60
E2000-0300 T3	72	25	80A	80A	JJS80
E2000-0370 T3	85	35	125A	90A	JJS90
E2000-0450 T3	110	35		125A	JJS125
E2000-0550 T3	132	50	160A	175A	JJS175
E2000-0750 T3	180	95	200A	200A	JJS200
E2000-0900 T3	220	120	250A	250A	JJS250
Control cables – all framesizes		0,75-1 AWG20 /2,7			

Earth/ground connection

Minimum earth/ground wiring cross section – for terminal connection

Motor wiring section: S (mm ²)	Minimum earth wiring cross section \neq /PE/E (mm ²)
S ≤ 16	= S
16 < S ≤ 35	min 16
S > 35	min S/2

Minimum earth/ground wiring cross section – for chassis connection (on designed "G" "GND" "GROUND" connection points)

Motor wiring section: S (mm ²)	Minimum earth wiring cross section \neq /PE/E (mm ²)
S ≤ 16	AWG8 / 6,2

Control terminals – control board

Two different configurations of control terminals and control boards are available, depending on inverter frame size

Inverter size E1 – E6
0,20...22 kW

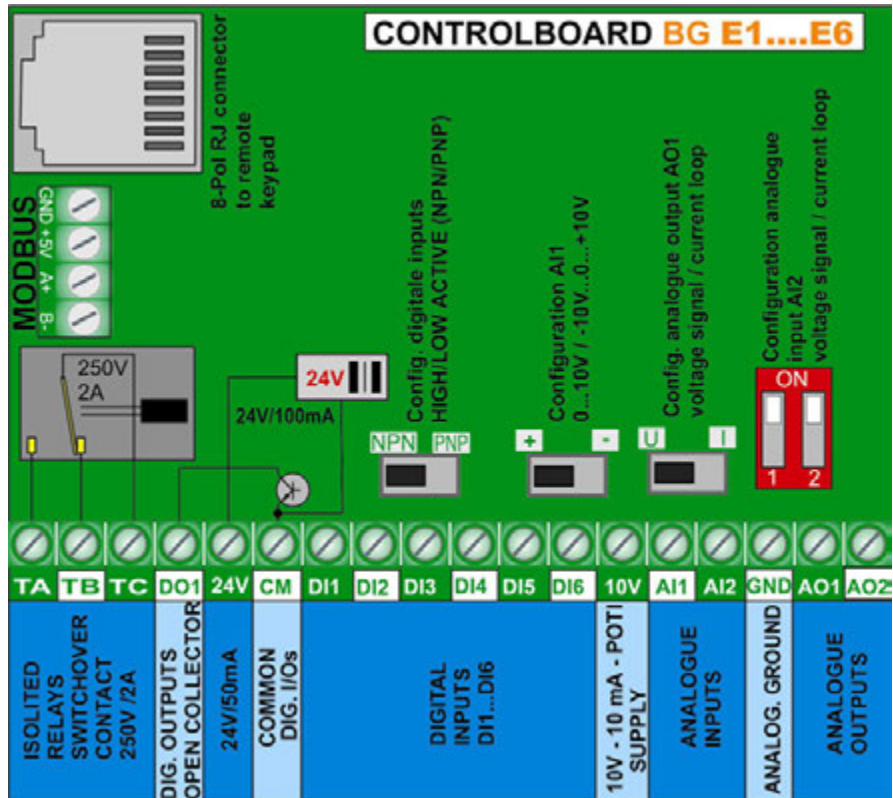

Inverter size C3 – C6
30....400 kW

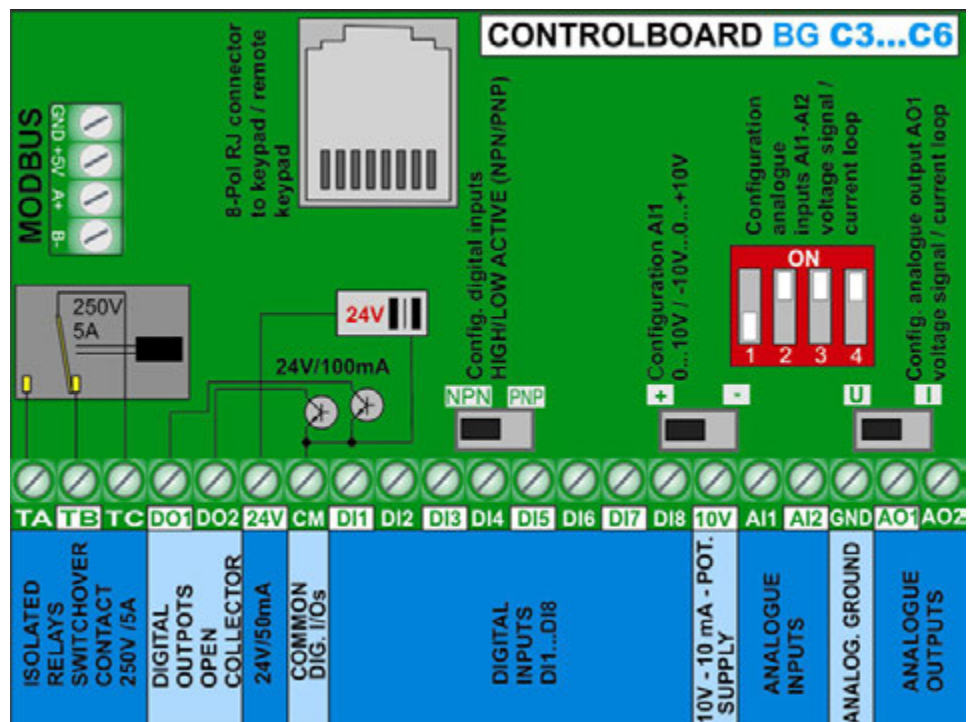

Control terminal function and factory default configuration

Main terminal

Terminal	Type	Description	Hardware data	Related parameter	DEFAULT setting
DO1	Digital / analogue outputs	Programmable digital output 1	Open-Collector output, max. 100mA-24V (referred on CM) – Pulse output	(F301) (F303)	Message F=>0Hz
DO2		Programmable digital output 2	Open-Collector output, max. 100 mA-24V (referred on CM)	(F302)	Message F>0Hz
TA TB TC		Digital Relays output - isolated switchover contact	TC=COMMON TB=NORMAL CLOSED TA=NORMAL OPEN Max. Contact load: Inverter 22 kW and below: 2A/230VAC - above 22 kW: 5A/230V	(F300)	Fault signal
AO1		Programmable analogue output 1	To configure for voltage/current signal (reference: analogue ground GND) For current signal: set SWITCH to „I“	(F413---F426) (F431)	Output frequency 0...10V
AO2		Programmable analogue output 2	Current signal 0(4)...20 mA (reference analogue ground GND) >22kW only	(F427----F430) (F432)	Motor current 0...20mA
10V	DC 10V	10V, referred on analogue ground	10V supply for potentiometer or similar, max. current 20 mA		
AI1	Analogue - Inputs	Programmable analogue input 1	Set-point – current/voltage input for configuration see: <i>(Hardware and configuration of I/O channels)</i>	(F400-F405) (F418)	0...10V
AI2		Programmable analogue input 2	Set-point – current/voltage input for configuration see: <i>(Hardware and configuration of I/O channels)</i>	(F406-F411) (F419)	0..20 mA
GND		Analogue ground	Microprocessor ground, reference point for all analogue signals		
24V	DC 24V	Isolated 24V power supply	24±1.5V, to CM; limited to 50mA, for powering of digital I/Os		
DI1	Programmable digital inputs	Programmable digital input 1	HIGH/LOW active (NPN/PNP) selectable via hardware - see: <i>(Hardware and configuration of I/O channels)</i> Pulse signal input	(F316)	Jog mode FWD
DI2		Programmable digital input 2	HIGH/LOW active (NPN/PNP) selectable via hardware - see: <i>(Hardware and configuration of I/O channels)</i> (DI7 – DI8 on inverters above 22 kW only)	(F317)	Emergency stop external signal
DI3		Programmable digital input 3		(F318)	Terminal (FWD)
DI4		Programmable digital input 4		(F319)	Terminal (REV)
DI5		Programmable digital input 5		(F320)	RESET
DI6		Programmable digital input 6	All digital I/O are floating, including 24V supply and CM	(F321)	Power stage enable
DI7		Programmable digital input 7		(F322)	START
DI8		Programmable digital input 8		(F323)	STOP
CM	COMM	Common for digital I/O	Common for digital inputs and 24V aux. supply		

RS485 Terminal

GND	RS 485	Analogue ground	Microprocessor ground, reference point for all analogue signals		
+5V		5V, 50 mA	5 V supply microprocessor level		
A+		Differential signal, positive	Standard: TIA/EIA-485(RS-485) Interface protokol: MODBUS Bd.Rate: 1200/2400/4800/9600/19200/38400/57600	(F900-F904)	9600
B-		Differential signal, negative			

Sample set-up for inverter 22 kW, 400V - framesize E6

If parameter status is unknown, factory reset is recommended: Set parameter **F160 = 1**

Analogue speed reference 0...10V (potentiometer) through input channel **AI1**: Set **F203=1**
 START/STOP command and inversion through terminal signals: set **F208=2** (two wire control)
 Fault signalling on relays contact: **F300=1** (already default set)
 „Inverter enabled“ message on **DO1** **F301=14** (already default set)
 Frequency indication output: **AO1** 0...10V = 0-50 Hz **F423=1**, **F431=0** (already default set)

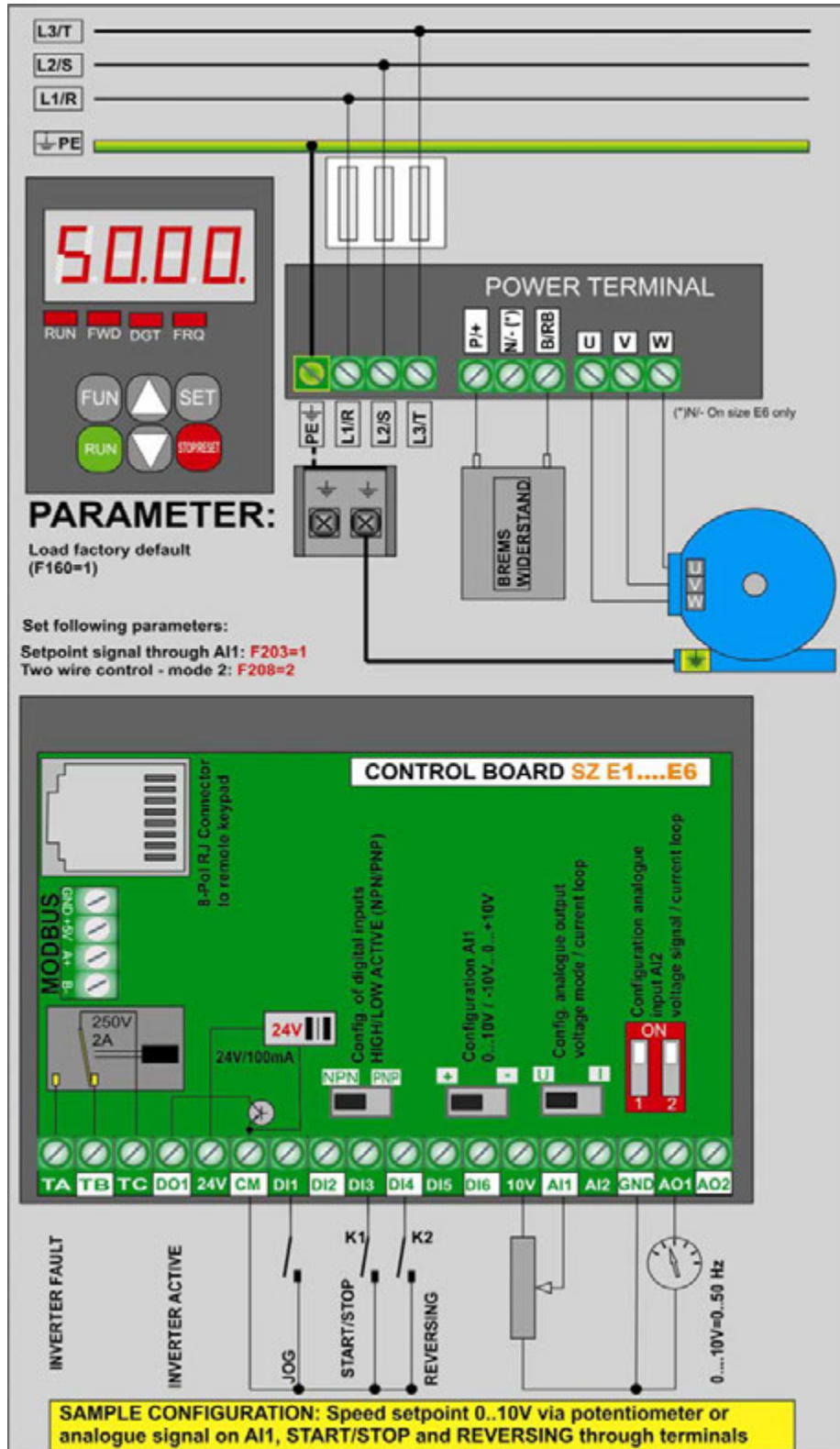

5) Control-board: hardware and I/O channel configuration

I/O channel configuration is a combination of hardware and software setting

For software parameter setting see chapter:

10) Parameter group 300: Configuration of digital I/O channels

11) Parameter group 400: Configuration of analogue I/O channels

Two different type of control boards are used in E2000+ inverter concept:

Control board for inverter, power range 0,4 - 22 kW: Framesize E1 - E6

Control board for inverter, power range 30kW - 400 kW: Framesize C3 - C6

Control-board inverter

0,4...22kW

SIZE E1 - E6:

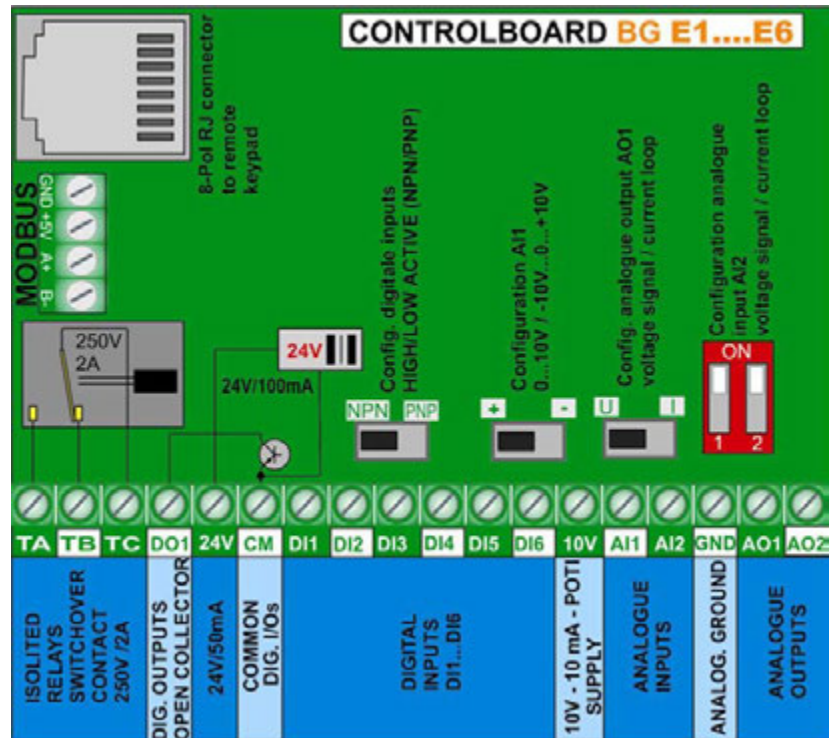

Digital input channels: E1 - E6:

A total of 6 digital input channels DI1....DI6 are available on inverter, size E1-E6. Different functions can be assigned to these inputs, programming the parameter F316....F321 – description: see chapter 10) Parameter group 300: Configuration of digital I/O channels

DI1 is preset for digital input and fast pulse signal input as well.

Attention: A function can be assigned to one single digital input only (no multiple inputs for same function allowed) if a function is already assigned to a certain input (due to factory set), this assignment must be deleted (set function-code 0), before assigning to another input.

HIGH/LOW active (PNP/NPN) control-mode selection: This selection is done via hardware setting of the NPN-PNP DIP-SWITCH on the control board.

All digital inputs are isolated from analogue ground, the 24 V (50mA) auxiliary power supply may be used for input control in PNP mode. CM is the common reference point for all digital inputs.

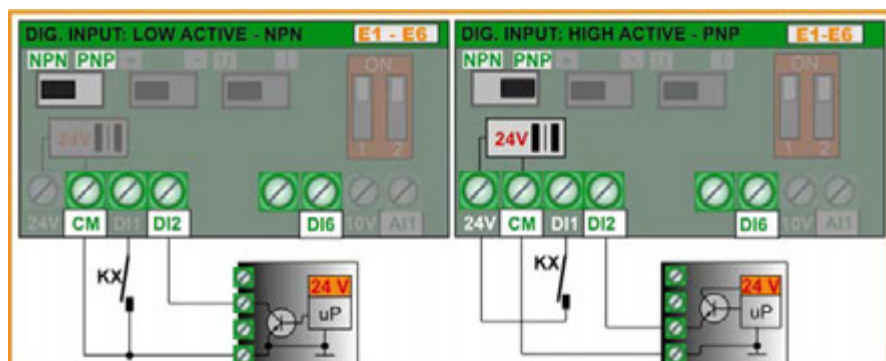

Factory setting: NPN

Analogue input channels: E1 - E6:

E2000+ inverters SIZE E1...E6 have two independent analogue input channels AI1 and AI2, both have a resolution of 12 Bit.

Signal level configuration is done by hardware setting on the control board, and corresponding parameter setting.

For software parameter setting see: 11) *Parameter group 400: Configuration of analogue I/O channels*

AI1 Voltage signal input: programmable for 0...10V or -10V...0...+10V (factory-default setting 0...10V)

AI2 Voltage/Current signal input: to configure for 0...5V, 0...10V or 0...20 mA - (4...20 mA: offset, to set via software parameter – F406, F408) – (factory-default setting 0...20 mA)

Configuration AI1

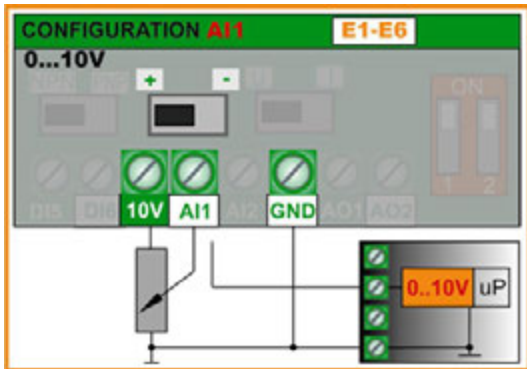

Factory default setting: 0...10V

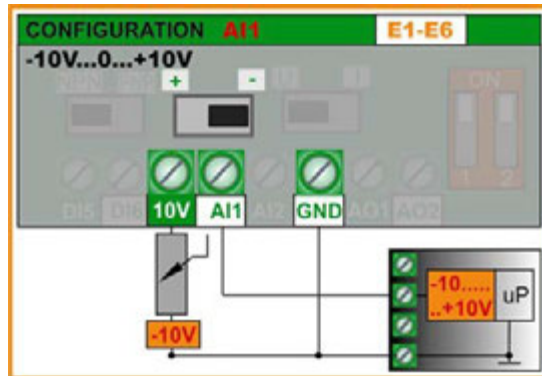

Configuration AI2

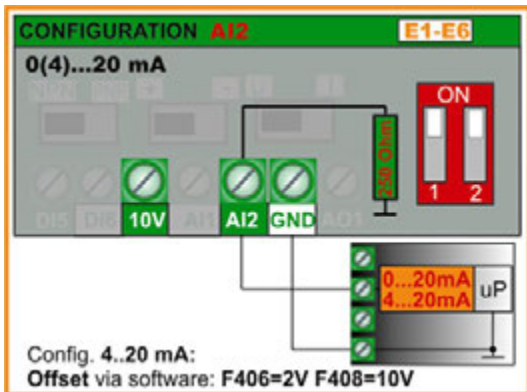

Factory default setting: 0...20mA

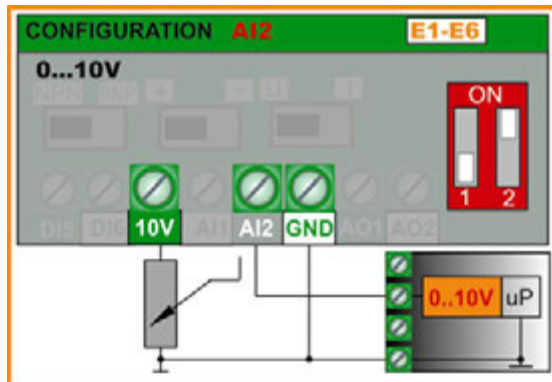

Input impedance for voltage control: 10 kOhm
 Burden resistor for current loop: 500 Ohm

5) Control board – hardware and I/O channel configuration

Digital output channels: E1 - E6:

Inverters of the E2000+series, SIZE E1...E6 have one relay contact output, and one open collector output DO1, both are free programmable for different functions, assignment codes are set in parameters F300 – F301.

TA-TB-TC Relay output: isolated switch over contacts, max. contact-load: 2A 230V (F300)

DO1 Digital output: OPEN COLLECTOR, referred to CM - U/High=24V, max. sink-current 100mA. (F301)
DO1 may work as fast pulse signal output too, set via parameter F303. max. frequency 50 kHz, $U_{ss}=24V$

Analogue output channels: E1 - E6:

Two analogue output channels are available on inverters E2000+ SIZE E1-E6: AO1 and AO2.

AO1 : To configure for **voltage** or **current loop** signal – function assignment code: F431, signal conditioning F423, range setting F424 - F426

Software parameter F423...F434, for signal type configuration and function assignment – see chapter: *Parameter group 400*

Following hardware setting is necessary for AO1 (voltage signal / current loop selection):

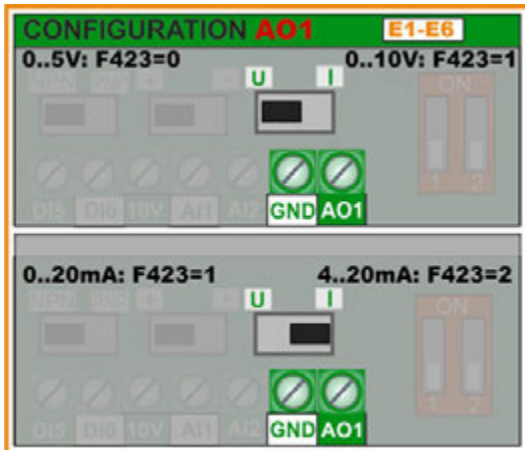

Factory default setting: 0...10V

AO2: Fixed for **current loop**
(Signal conditioning: F427 – range setting: F428 - F430)

Function assignment code F432

Factory default setting: 0...20mA

Control-board inverter
30...400kW
 SIZE C3 – C6:

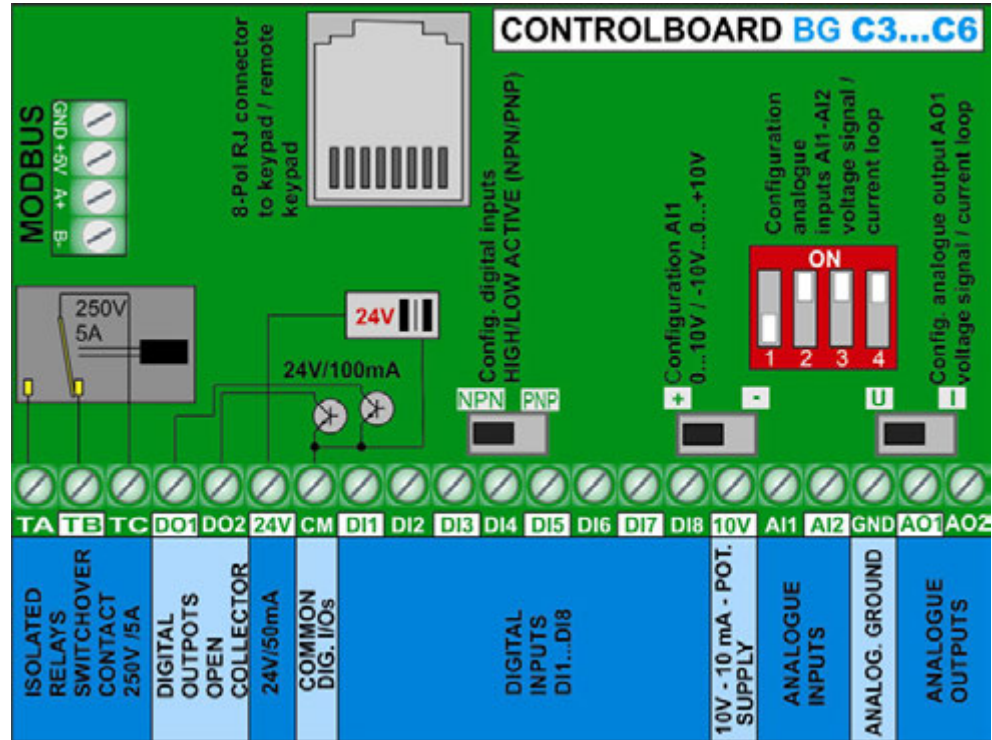

Digital input channels: C3 – C6:

A total of 8 digital input channels DI1....DI8 are available on inverter, size C3-C6. Different functions can be assigned to these inputs, programming the parameter F316....F323 – description: see chapter 10) *Parameter group 300: Configuration of digital I/O channels*

DI1 is preset for digital input and fast pulse signal input as well.

Attention: A function can be assigned to one single digital input only (no multiple inputs for same function allowed) if a function is already assigned to a certain input (due to factory set), this assignment must be deleted (set function-code 0), before assigning to another input.

HIGH/LOW active (PNP/NPN) control-mode selection: This selection is done via hardware setting of the NPN-PNP DIP-SWITCH on the control board.

All digital inputs are isolated from analogue ground, the 24 V (50mA) auxiliary power supply may be used for input control in PNP mode. CM is the common reference point for all digital inputs.

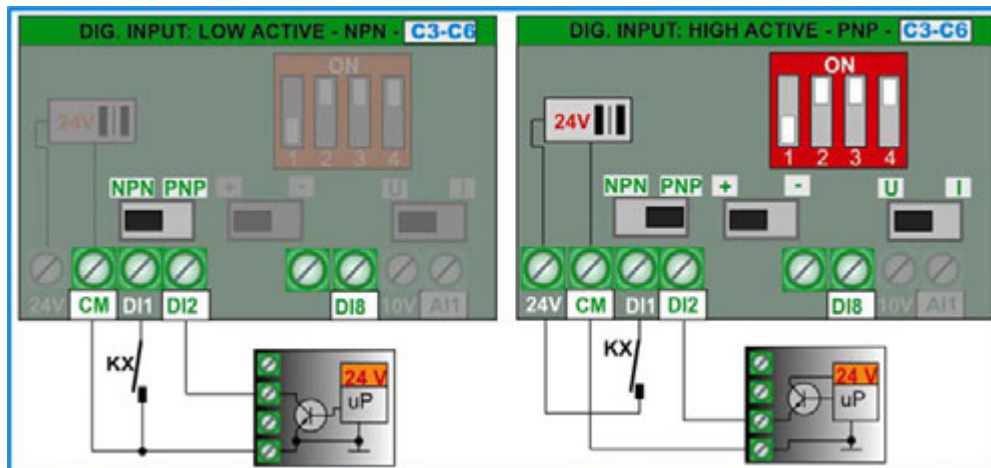

Factory default setting: NPN

Analogue input channels: C3 – C6:

E2000+ SIZE C3...C6 have two independent analogue input channels **AI1** and **AI2**, both have a resolution of 12 Bit. Signal level configuration is done by hardware setting on the control board, and corresponding parameter setting

For software parameter setting see: 11) *Parameter group 400: Configuration of analogue I/O channels*

AI1 - Voltage signal / current loop: programmable for 0...5V, 0...10V, -10V...0...+10V or 0...20 mA.
(4...20 mA: offset, to set via software parameter **F400**, **F402** - (factory-default setting 0...10V)

AI2 - Voltage signal / current loop: to configure for 0...5V, 0...10V or 0...20 mA.
(4...20 mA: offset, to set via software parameter – **F406**, **F408**) – (factory-default setting 0...20 mA)

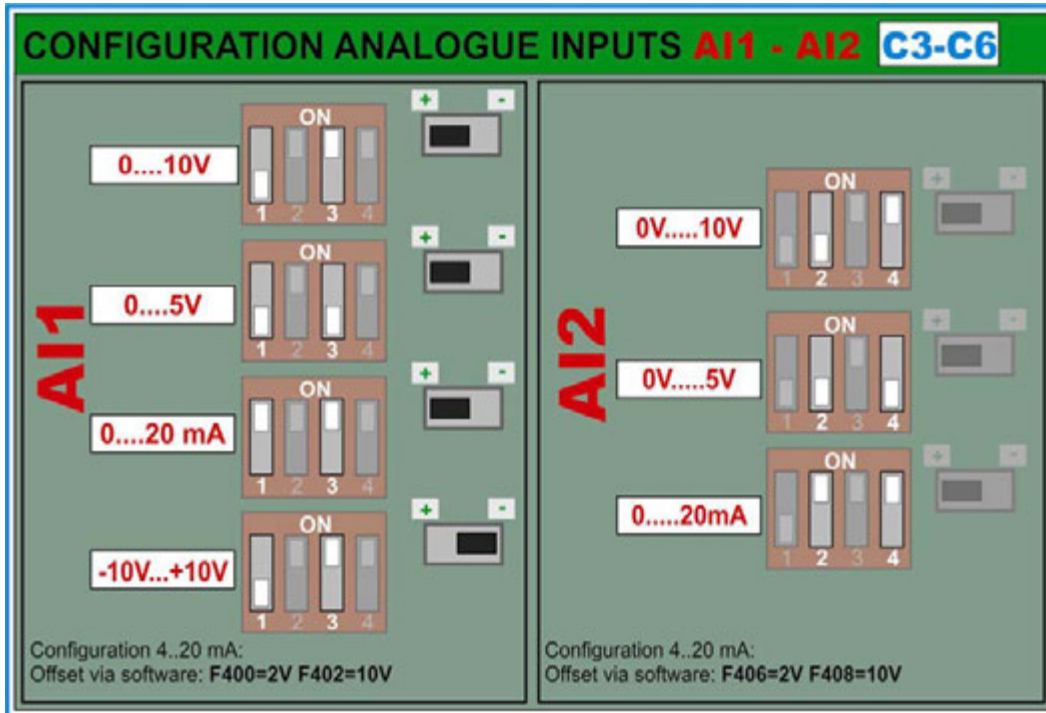

Factory default setting:
AI1: 0...10V
AI2: 0...20mA

Input impedance for voltage signal: 10 kOhm

Burden resistor for current loop control: 500 Ohm

5) Control board – hardware and I/O channel configuration

Digital output channels: C3 – C6:

Inverters of the E2000+ series, SIZE C3...C6 have one relay contact output, and two open collector output DO1 and DO2, both are free programmable for different functions, assignation codes are set in parameters F300 – F302.

TA-TB-TC Relay output: isolated switch over contacts, max. contact-load: 5A 230V (F300)

DO1 Digital output: OPEN COLLECTOR, referred to CM - U/High=24V, max. sink-current 100mA. (F301)
DO1 may work as fast pulse signal output too, set via parameter F303 max. frequency 50 kHz, U_{ss}=24V

DO2 Digital output: OPEN COLLECTOR, referred to CM - U/High=24V, max. sink-current 100mA (F302).

Analogue output channels: C3 – C6:

Two analogue output channels are available on inverters E2000+ SIZE C3 - C6: AO1 and AO2. Different functions can be mapped to both channels

AO1 : To configure via hardware for **voltage signal** or **current loop** – (signal conditioning F423, range selection F424-F426)

Function assignation code: Parameter F431

Following hardware settings are necessary for AO1

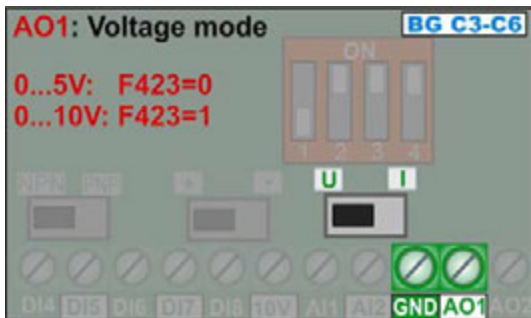

Factory default setting: 0...10V

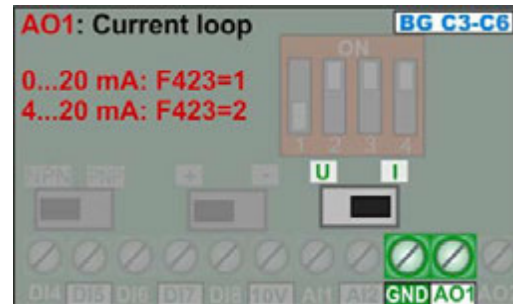

AO2 : Output for **current loop** signal (signal conditioning: F427, range setting: F428 - F430)

Function assignation code: F432

Factory default setting: 0...20mA

Motor protection using PTC/KLIXON: For all inverter size E1 - E6 and C3- C6

For simple applications and short motor cables (<5m) the digital inputs **DI1...DI6 (8)** can be used as PTC/NTC/KLIXON signal input channel.

For hardware set-up, see picture below, the value of the resistor depends on the PTC value, if KLIXON is used for motor protection, a 1 kOhm resistor, 1 WATT is recommended. Each digital input is programmable for PTC/KLIXON signal evaluation

The trigger threshold is about 4 V – it means about 20V input signal level for PNP configuration - about 4V input signal level for NPN configuration.

If triggered, **OH1** is the error code shown on the display

Function assignment parameter F316...F323:
code: 37 for normal open contact (NTC)
code: 37 for normal closed contact (PTC)

ATTENTION!!! Provide adequate insulation between PTC/KLIXON circuit and motor phases

Switching threshold for PTC:
For the configuration on right: about 20V between CM and DIx, this corresponds to a PTC resistance value of 6 kOhm

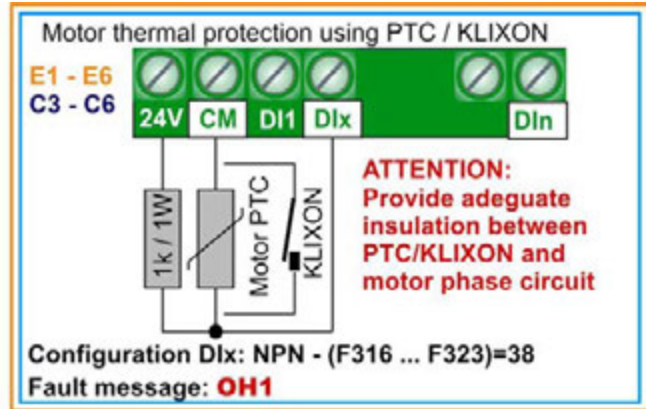

Power supply for passive current loop sensor:

A minimum driving voltage of 20 V is required for common passive 2 wire sensors connected to burden resistor of 500 Ohm. If such sensors are in place, the internal 24 V supply can be used, however, the digital ground must be connected to the analogue ground (CM - GND).

Galvanic separation will become lost in this case. This may create more noise on control inputs. Therefore all control cables must be shielded and wired in sense of EMC standards, especially, if the cable length exceeds the 5 meters.

If digital / analogue ground separation is required, a 24V DC/DC converter is recommended

The schematic below shows the wiring for a passive 4...20 mA sensor

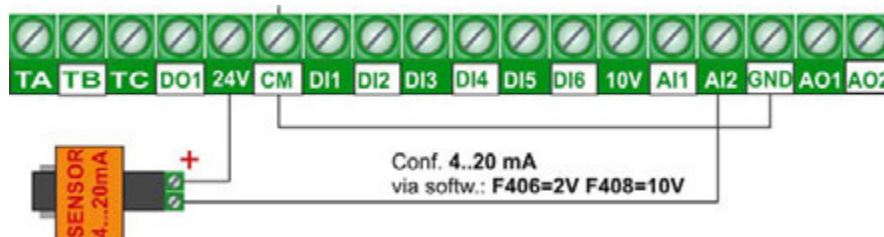

6) Operating panel

Inverter control, parameter setting, operating-parameter display and inverter-status information are all done through the operation panel.

A seven segment, 4-digit display, combined with six button keypad field and 4-LED status line is build in on front of E2000+ inverters.

An optional build-in potentiometer is available

The adjacent picture shows the standard unit:

7-segment display, status LED and keypads



7-segment display:

The content of the display can be configured, to show different operating parameters, while inverter in STOP or START mode, error messages, parameters and parameter values (for configuration see chapter: Parameter group 100 – BASIC parameter)

The **FUN** key is used to cycle through all programmed content, including parameter level.

(Configuration parameter on display have always a leading *F*).

Faults are displayed with the respective error code.

Flashing numbers in STOP mode indicate the target-frequency, which the inverter will reach after START command is given.

Status LED:

To display the inverter status:

Inverter in START mode. Display shows the programmed working parameters	To indicate the rotating direction	Toggle with STOP/RESET key, if ON, single step modus is selected for parameter cycling	ON, if the number on the display corresponds to output frequency

Key and function

Cycling through different display content	START command	STOP command Toggle switch for DGT ERROR RESET	Parameter: Selection, and save	Increment / Decrement Key

Display of function parameters and error codes

DISPLAY	DESCRIPTION
HF-0	Jog mode via keypad is selected
-HF-	RESET, POWER-ON process
OC OC1 OC2 GP OE OL1 OL2 OH LU PFO PF1 OH1 CE FL AErr EP/EP2/EP3 nP PCE EEEE ERR0 ERR1 ERR2 ERR3 ERR4 ERR5 ERR6	ERROR codes, description see chapter (<i>Parameter group 700: Error handling and protection functions</i>)
ESP	External EMERGENCY STOP has been triggered
F 152	The leading <i>F</i> displays configuration parameter number (Parameter Nr. 152)
10.00	Output frequency (if FRQ=ON), operating parameter, configuration parameter value
50.00	Flashing numbers in STOP mode: Target frequency/speed after START command is given
0.	Dead band during rotation direction change
A100 U100, b*.*, o*.*y, L*.*H*.*	Operating parameters in START / STOP mode: Motor current, Motor voltage, DC-voltage, Temperature PID-controller feed-back value.....for programming: see parameter F131 – F132
STO	STO Save Torque Off mode activated by optional STO board

Remote operating panel

Inverter 0,2...22kW – SIZE E1-E6: The display is integrated in the control board, the keypad is part of the inverter-cover. The optional remote keypad is connected through the lateral MODBUS connector, using standard 8 pole Cat.5 RJ LAN cable
Remote keypad type: **A6-1-A – required cabinet mounting hole: 70x120mm**
Parameter **F421** is used to set working mode: Both keypads or remote keypad only

Inverter 30...400kW – SIZE C3-C6: The keypad/display unit is removable, connection to the control-board is made via 8 pole RJ style cable. An optional mounting frame for the remote unit is available as option. Standard LAN cable (Cat.5, 8 pole) can be used for remote connection.

Maximum cable length for remote keypad: 10m

7) Parameter setting

For easier parameter setting, the whole parameter list is divided into 11 parameter groups:





Parameter type	Parameter. Nr. Range	Group
BASIC parameter	F100 - F160	100
Inverter control, set-point source setup	F200 - F280	200
Function assignation to digital I/Os - diagnosis	F300 - F340	300
Analogue I/O signal configuration	F400 - F473	400
Fixed-frequency control, cycle control	F500 - F580	500
DC-Brake, limiting functions, auxiliary functions	F600 - F677	600
Fault handling – configuration of protection function	F700 - F760	700
Motorparameter, AUTOTUNING	F800 - F880	800
Serial link parameter set	F900 - F926	900
PID controller parameter, pump control functions	FA00 - FA80	A00
Torque / speed control	FC00 - FC51	C00
Reserved	FE00 - FE60	E00
Reserved	H000 - H019	000



Selection of parameters, modification and saving:

The **FUN** key toggles between all different values on the display.

F as prefix signify parameter level and the number refers to a parameter.

Once on parameter level, the   keys are used to flip through parameters.

 key toggles between single and multi parameter step. If  is on, single mode is selected, if off, group mode is selected, and   keys moves in steps of 100.

SET key selects the parameter on the display, and the parameter value is shown. The blinking digit may be changed, using   keys (eventually use  key to switch through single digits). Pressing **SET** again memorizes the modified parameter value.

Parameter types:

Read only parameters: These parameters can not be changed, the tentative to modify will end up in **Err0** message – read-only parameters are listed in **GRAY characters**

Dynamic parameters: These parameters are allowed to modify with inverter in **START** and in **STOP** mode, listed in red bold characters on this description: **Fxxx**

Static parameters: To modify with inverter in **STOP** mode only, otherwise, **Err0** is displayed, static parameters are listed in red, italic bold characters as ***Fxxx***

If parameter setting is not successful, **Err0** will show up on the display

Factory parameter reset: F160=1 (see chapter parameter group 100)

8) Parameter group 100: Basic parameter

F100 Passwort	Range: 0 – 9999	Default: 8
----------------------	-----------------	------------

If F107=1 (password enabled): enter correct password, to unlock parameter modification function. Incorrect password results in **Err1** on the display

F102 Rated current (A)	Range: 1.0 – 800.0	Factory set, depending on model, read only
F103 Rated power (KW)	Range: 0.2 – 800.0	Factory set, depending on model, read only

F105 Software version No.	Range: 1.00 - 10.00	Factory set, depending on model, read only
----------------------------------	---------------------	--

F106 Control algorithm	Selection: 0: Sensorless Vector (SLV) 1: Reserved 2: V/Hz mode 3: Simple Vector (Slip compensation) 6: Synchronus motor control	Default setting: 2
-------------------------------	--	--------------------

- 0: SENSORLESS VECTORS can operate with one single motor only
2: V/Hz mode can work with more motors in parallel connection
3: Simple Vector Modus can operate with one single motor only
6: Control of PMM - Permanent Magnet Synchronus motors (single motor only)

Attention!!

All motor parameters must be set precisely, to guarantee correct function in SENSORLES VECTOR control mode (F106=0/3). Motor parameters can be set manually (see parameter group 800), The AUTOTUNING function is used to fine-tune parameters.

For drives applications with quadratic torque characteristic (pump, fan) the V/Hz setting is recommended (F106=2). Inverter rated power should match motor power. Catch on the fly function is in V/Hz mode available only.

F107 Activation of password protection (for parametrizing)	Selection: 0: No password protection 1: Password protection	Default setting: 0
F108 Password setting	Range: 0 - 9999	Default setting: 8

F109 Start – frequency (Hz)	Range: 0.00 - 10.00 Hz	Default setting: 0.00 Hz
F110 Start – frequency duration (sec.)	Range: 0.0 - 10.0 sec.	Default setting: 0.0 sec.

The inverter always starts running with the selected Start-frequency, if the target frequency is lower than the Start-frequency, **F109** will be ignored.

After the inverter gets a START command, it will remain at the Start-frequency, (set in **F110**), for the time, set in **F111**. After the delay, it will proceed with the acceleration ramp to reach the final frequency. The acceleration ramp does not take into account the start frequency delay time

The Start-frequency value is independent and not limited by the minimum frequency **F112**. In case **F109** is lower, than **F112**, the inverter will start running with the values in **F109** and **F110**. After the inverter reaches the minimum frequency **F112**, the values **F111** and **F112** are considered as frequency limits.

It is recommended, to chose Start-frequency lower than maximum frequency (**F111**).

F111 Maximum frequency (Hz)	Range: F113 - 650.0 Hz	Default setting: 50.00Hz
F112 Minimum working frequency (Hz)	Range: 0.00 - F113 Hz	Default setting: 0.50Hz

The parameter **F111** limits the inverter output frequency

In SENSORLESS VECTOR mode it is recommended to limit the maximum frequency to 400 Hz

The parameter **F112** defines the minimum allowed output frequency. If speed reference corresponds to frequency lower than the value in **F112**, the inverter behaviour depends on Parameter **F224**: **F224=0**: Inverter stops, **F224=1**: Inverter continues to run on F-min, defined by **F112**.



Attention!! Continuous operation at low speed may overheat the motor – forced ventilation is recommend

8) Parameter group 100: Basic parameter

F113 Internal speed reference (Hz)	Range: F112 - F111	Default setting: 50.00 Hz
---	---------------------------	----------------------------------

Virtual internal speed reference, it is selectable in the same way, as any external speed reference (see F203, F204). If selected **F203/204 = 0**, after the START command, the inverter will reach this speed value.

F114 Acceleration ramp 1 (sec.)	Range: 0.1 – 3000 sec.	Default setting: 0.2 - 3.7KW, 5.0 sec. 5.5 - 30KW, 30.0 sec. > 37KW, 60.0 sec.
F115 Deceleration ramp 1 (sec.)		
F116 Acceleration ramp 2 (sec.)		Default setting: 0.2 - 3.7KW, 5.0 sec. 5.5 - 30KW, 30.0 sec. > 37KW, 60.0 sec.
F117 Deceleration ramp 2 (sec.)		

Acceleration ramp: Time to reach 50 Hz, or F-max (it depends on F119)

Deceleration ramp: Time, to decelerate to 0 Hz, referred to 50 Hz, or F-max (depending on F119)

The second ramp set is selectable via programmable digital input (DI1...DI8) - (F316...F323).

F119 Reference for Accel./Decel. ramp time	Selection: 0: 0 ... 50.00Hz 1: 0 ... F-max	Default setting: 0
---	---	---------------------------

If **F119=0**, ramp time is the duration from 0 Hz to 50 Hz, If **F119=1** it is from 0 Hz to F-max.

F118 Knee frequency (Hz)	Range: 15.00 - 650.0	Default setting: 50.00Hz
---------------------------------	-----------------------------	---------------------------------

Frequency, corresponding to the maximum inverter output voltage, the U/F characteristics reaches the horizontal range
Below the knee-frequency, the drive system operates in constant torque, above it works with constant power



ATTENTION!! Wrong setting of the Knee-Frequency may destroy the motor

F120 Dead time during reversion (sec.)	Range: 0.0 – 3000 sec.	Default setting: 0.00 sec.
---	-------------------------------	-----------------------------------

If activated (>0), the inverter will stop at 0Hz during the reversing cycle, indicated as **0.** on the display. (these parameter has no effect, if automatic frequency cycling is chosen).

This function may be useful, to avoid torque/current peaks during reversion

F122 Reverse operation disable	Selection: 0: reversion enabled 1: reversion disabled	Default setting: 0
---------------------------------------	--	---------------------------

if **F122=1** the inverter can operate in one rotating direction only, regardless of different other settings or control signals. A reversing command will result in inverter STOP

If inverter rotation is set to "reverse" by parameter (F202=1), and F122 is set to "reversing disable", the inverter will not start

If "Catch on the fly" function is active, it will catch the motor, beginning with 0.0 Hz

F123 Reversing enable with combined speed control	Selection: 0: disable 1: enable	Default setting: 0
--	--	---------------------------

If in case of combined speed control, the speed result becomes negative (reverse rotation), this function may be used to enable/disable the reverse rotation of the motor. If disabled, in case of negative speed, the inverter output 0,0 Hz (Parameter **F122=1** overwrites this setting)

8) Parameter group 100: Basic parameter

F124 Jog frequency (Hz)	Range: F112 - F111	Default setting: 5.00 Hz
F125 Accel. ramp – Jog Mode (sec.)	Range: 0.1 – 3000 sec.	Default setting: 0.2 - 3.7KW: 5.0 sec. 5.5 - 30KW: 30.0 sec. > 37KW: 60.0 sec.
F126 Decel. ramp –Jog Mode (sec.)		

There are two modes to activate the Jog frequency: Keypad-control, and terminal-control (programmable digital inputs DI1...DI6(8) – configuration: F316...F323).

Keypad-control: With the inverter in STOP mode press  key, to display HF-0, in this condition the  key works as a Jog frequency start/stop toggle (F132 must be configured in the proper way 1+x+x+x).

Terminal control: A proper configured digital input works as Jog frequency start/stop toggle

Remark: In Jog mode the "catch on the fly" function is deactivated

F127/F129 Cut-Off frequency A,B (Hz)	Range: 0.00 - 650.0	Default setting: 0.00 Hz
F128/F130 Cut-Off frequency window A,B (Hz)	Range: ±2.5 Hz	Default setting: 0.0 Hz

Cut-Off frequency to avoid resonance problems – the inverter transits during accel. / decel. ramps through this frequency areas, but it can not stay stable within this frequency ranges.

Display configuration:

F131 Display: Selection of operating parameters to display during „START“ status (Motor running)	0: Output frequency / parameter value	Default setting: 0+1+2+4+8=15 (frequency+speed+motor-voltage+motor-current+DC-voltage)
	1: Motor speed (rpm)	
	2: Motor current	
	4: Motor voltage	
	8: DC-voltage	
	16: PID control feed back	
	32: Heatsink temperature	
	64: Counter	
	128: Speed (linear - calculated)	
	256: PID set-point	
	512: Reserved	
	1024: Reserved	
	2048: Motor-Power	
	4096: Motor-Torque	
	8192: Reserved	

To display a specific parameter, just set Parameter F131 to one of the values in the table above, to display more parameters, the sum of all values must be set in F131

The  key is used to cycle through the various selected parameter values

8) Parameter group 100: Basic parameter

<p>F132 Display: Selection of operating parameters to display during „STOP“ status (Motor stopped)</p>	<p>0: Target frequency / Parameter (Fxxx) 1: Jog modus via keypad - HF-0 2: Target motor speed (rpm) 4: DC-voltage 8: PID control feed back 16: Heatsink temperature 32: Counter 64: PID set-point 128: Reserved 256: Reserved 512: Torque control reference 1024: Reserved 2048: Reserved</p>	<p>Default setting: 0+2+4=6</p>
---	--	---

With inverter in STOP mode, the display will always show the target frequency - flashing

Following table shows the units and display-mode for various parameters:

- Motorspeed (rpm): **(NNNN)** integer value – the decimal point indicates values above 9999.
- Motor Current **A (A.A)**
- Motor-Voltage: **U (VVV)**
- Counter status: **(ZZZZ)**
- DC-Voltage: **u (VVV)**
- Heatsink temperature: **H (TTT)**
- Calculated speed **L(sss)**. Decimal point to indicate values above 999, two decimal points for values above 9999
- PID controller Set-Point (normalized): **(o*.*)**
- PID Feed-Back (normalized): **(b*.*)**
- Motor-Power (normalized): **(x.x)**
- Motor-Torque (normalized): **(m.m)**

Single phase inverter size E1 (0.2 - 0.75KW) do not have temperature indication.

Parameter, for calculated speed indication (display)

<p>F133 Transmission ratio</p>	<p>Range: 0.10 - 200.0</p>	<p>Default setting: 1.00</p>
<p>F134 Pulley diameter</p>	<p>0.001 – 1.000 (m)</p>	<p>Default setting: 0.001</p>

Example: Max. Frequency **F111=50.00Hz**, number of poles **F804=4**, transmission ration **F133=1.00**, pulley diameter R=0.05m (**F134=0,05**), calculation result: pulley circumference: $2\pi r = 2 \times 3.14 \times 0.05 = 0.314$ (meter), shaft speed: $60 \times \text{frequency} / (\text{number of poles} \times \text{transmission ratio}) = 60 \times 50 / (2 \times 1.00) = 1500 \text{rpm}$. For linear speed: $\text{speed (rpm)} \times \text{pulley circumference} = 1500 \times 0.314 = 471 \text{(meter/second)}$

8) Parameter group 100: Basic parameter

F136 Slip compensation in V/Hz mode	Range: 0 - 10%	Default setting: 0
--	-----------------------	---------------------------

This parameter compensates the load-dependent slip of the asynchronous motor – it works only in the stable area of the motor speed/torque characteristic
during the "catch on the fly" process this function is deactivated

F137 Voltage frequency characteristic (for V/Hz mode only)	Selection: 0: Linear 1: Quadratic 2: User defined (6 - Punkt) 3: Automatic 4: Defined by separate voltage setpoint	Default setting: 3
F138 Lineare characteristic	Range: 1 - 20	Default: 0.2-3.7 kW : 7 5.5-30 kW : 6 37-75 kW : 5 > 90 kW: 3
F139 Quadratic characteristic	Auswahl: 1 - 6	Default setting: 1

Voltage increase on low frequencies is necessary to compensate the stator copper resistance.

With **F137=0 linear** voltage increase is chosen, suitable for constant torque load.

F137=1 quadratic increase, the right curve for load with quadratic characteristic, like pump and fan.

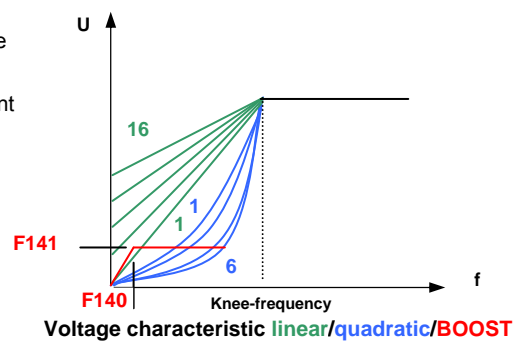

Voltage characteristic linear/quadratic/BOOST

F137=2, serves to possible to program a user specific V/Hz curve – see table below

A total of 12 parameter are necessary to define the user specific curve (**F140 bis F151**).

F140 User defined frequency F1	Range: 0 - F142	Default setting: 1.00
F141 Assigned motor voltage V1	Range: 0 - 100%	Default setting: 4
F142 User defined frequency F2	Range: F140 - F144	Default setting: 5.00
F143 Assigned motor voltage V2	Range: 0 - 100%	Default setting: 13
F144 User defined frequency F3	Range: F142 - F146	Default setting: 10.00
F145 Assigned motor voltage V3	Range: 0 - 100%	Default setting: 24
F146 User defined frequency F4	Range: F144 - F148	Default setting: 20.00
F147 Assigned motor voltage V4	Range: 0 - 100%	Default setting: 45
F148 User defined frequency F5	Range: F146 - F150	Default setting: 30.00
F149 Assigned motor voltage V5	Range: 0 - 100%	Default setting: 63
F150 User defined frequency F6	Range: F148 - F118	Default setting: 40.00
F151 Assigned motor voltage V6	Range: 0 - 100%	Default setting: 81

Remark: $V1 < V2 < V3 < V4 < V5 < V6$, $F1 < F2 < F3 < F4 < F5 < F6$.

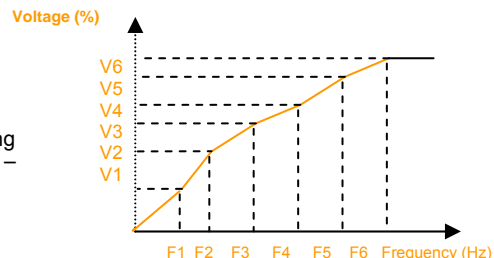

User programmable curve

If **F137=3**, the slip compensation works in automatic – correct setting for all motor parameter is necessary to guarantee correct operation – AUTOTUNING may be used to find motor parameters, like inductance and stator resistance (see parameter group 8).



WARNING!! High voltage increase on low speed may result in inverter over-current trip and/or motor overheating

8) Parameter group 100: Basic parameter

F140 BOOST knee-frequency (Hz)	Range: 0 – 5 Hz	Default setting: 1 Hz
F141 BOOST intensity (%)	Range: 0 – 25%	Default setting: 4 %

BOOST function allow additional voltage increase on low speed – see graphic (for F137=0 or F137=1).

F152 Maximum motor voltage (at knee frequency – modulation level)	Range: 10 – 100 %	Default setting: 100 %
--	--------------------------	-------------------------------

This function is used to limit the maximum motor voltage – the percentage value refers to the corresponding input voltage (on 400 V power supply: 100%= 400 motor voltage)

F153 PWM Frequency	Range:	Default setting:
	0.2 – 7.5 kW: 800 Hz – 16.000 Hz	0,2...7,5 kW: 4kHz
	11 – 15 kW: 800 Hz – 10.000 Hz	11...15 kW: 3kHz
	18.5 kW – 45 kW: 800 Hz – 6.000 Hz	18,5...45 kW: 4kHz
	>55kW: 800 Hz – 4.000 Hz	<55 kW: 2kHz

F154 Power supply voltage compensation	Selection: 0: deactivated 1: activated 2: deactivated during deceleration ramp	Default setting: 0
---	---	---------------------------

This function keeps the motor-voltage stable and independent from power supply voltage fluctuation. It may stretch the deceleration phase, therefore it can be deactivated during deceleration only (F154=2)

F155 Internal value for secondary speed reference	Range: 0...F111	Default setting: 0
F156 Polarity secondary speed ref. (direction)	Range: 0 (FWD) oder 1(REV)	Default setting: 0
F157 Secondary speed ref. readout		Read-only
F158 Secondary speed polarity readout		Read-only

Internal digital reference for secondary speed reference - analogue to F113

F159 „RANDOM“ PWM modulation	Selection: 0: constant PWM frequency 1: „RANDOM“ modulated PWM	Default setting: 1
-------------------------------------	---	---------------------------

If F159=0: Inverter works with constant PWM frequency (as set in F153)
159=1: PWM frequency is "random" over-modulated.

F160 Factory default reset	Selection: 0: Normal operation 1: Start factory default reset process	Default setting: 0
-----------------------------------	--	---------------------------

Factory default reset procedure:

Select parameter **F160**, press **SET**, original parameter F160 value is 0, press **UP** key to set F160 to **1** press **SET** again
After a few seconds all factory default parameters are restored.

The value in F160 returns to 0, after the restore process is completed.

ATTENTION:

The process will not reset to factory default the following parameters:

F400 F402 F406 F408 F412 F414 F421 F732 F742 F745 F901

9) Parameter group 200: Inverter control

START / STOP / running direction:

F200 START command source	Selection: 0: Keypad only 1: Terminal input only 2: Keypad + terminal input 3: Serial link (MODBUS) 4: Keypad + terminal + serial link	Default setting: 4
F201 STOP command source	Selection: 0: Keypad only 1: Terminal input only 2: Keypad + terminal input 3: Serial link (MODBUS) 4: Keypad + terminal + serial link	Default setting: 4

F200 and **F201** are used to set the mode for inverter starting and stopping – via keypad key, digital input on terminals, MODBUS commands, or a combination of all three. All signals are dynamic, input pulses, are sufficient, to start/stop the inverter. **This parameters are valid only, if F208=0 (default), if F208>0, this setting will be ignored**

Attention: RUN/STOP commands, as set in parameter F200 and F202 work with dynamic signals (pulses). In Europe it is more common to work with static signals (for safety reason). Therefore it is recommended to use RUN/STOP signals, defined by parameter F208 (two wire control)



F202 Rotation direction preset	Selection: 0: forward 1: reverse 2: depending on terminal signals	Default setting: 0
---------------------------------------	--	--------------------

If no other rotation direction signal (logic) present, the rotation depends on this parameter – e.g. in case of keypad control. Otherwise the direction depends on logical function of more direction signals

If (**F500=2**) – automatic frequency cycling – this parameter is ignored

Selection of speed reference sources:

F203 Primary speed reference source "X"	Selection: 0: Internal reference (F113) with automatic memory 1: Analogue input AI1 2: Analogue input AI2 3: Reserved 4: Fix-frequencies, terminal control (digital inputs) 5: same as 1, (F113) but no memory 6: Potentiometer in keypad (AI3) 7: reserved 8: reserved 9: PID controller output 10: MODBUS data	Default setting: 0
--	--	--------------------

F203=0: Inverter accelerates after the first START command to the frequency value F113, using   keys, or proper configured digital terminal inputs, the user can vary the frequency, after a STOP command, the last frequency value will be automatically memorized. To activate the memorizing function in case of power-down too, it needs to set **F220=1**.

F203=1 - F203=2: this is the setting for speed reference through analogue channels AI1-AI2. Analogue channels may be configured for 0..10V, -10V...+10V, or 0(4)..20mA (on 500 Ohm). Configuration via DIP Switches on control board (see chapter: 5 *Hardware und hardware configuration of I/O channels*). Default: **AI1** = 0...10V, **AI2** = 0...20 mA. To realize 4...20mA, an offset can be programmed: **F406=2V**.

F203=4: Up to 16 fix programmed frequencies, selectable via programmable digital inputs **DI1...DI5(8)**

F203=5: Same function as F203=0: Internal reference (**F113**), but no memory after STOP or power-down

F203=6: The keypad potentiometer works as speed reference signal (only for keypads with integrated potentiometer)

F203=9: PID controller output works as speed reference origin (for PID controller applications))

F203=10: Speed reference through serial link (MODBUS)

9) Parameter group 200: Inverter control

<p>F204 Secondary speed-reference source "Y"</p>	<p>Selection: 0: Internal reference (F155) – with memory 1: Analogue input AI1 2: Analogue input AI2 3:Reserved 4: Fix-frequencies, terminal control (digital inputs) 5: same as 1, (F155) but no memory 6: PID controller output 7: Potentiometer on keypad (AI3)</p>	<p>Default setting: 0</p>
---	---	----------------------------------

Secondary speed channel has the same function, as primary channel, if selected as the only reference. Setting parameter **F207**, both channels, primary and secondary can be concatenated each other.

If **F204=0**, the value in **F155** works as initial speed reference, if secondary channel is used alone, in this case the value in **F156** is ignored

If **F207=1** or **F207=3**: value in **F155** and **F156** are valid for the secondary speed reference source

F205 and **F206** determine the range of the secondary speed channel, if analogue channel AI1 or AI2 are used for sec. speed ref. input (F205=1 or 2)

If the potentiometer on the keypad panel is selected (F205=7), primary speed reference source is limited on fix-frequencies or MODBUS setting

It is not allowed to configure primary and secondary speed reference source through the same channel

<p>F205 Reference point for the range setting of the secondary speed reference channel, using AI1 or AI2</p>	<p>Selection: 0: referred on F-max 1: referred on the primary speed channel "X"</p>	<p>Default setting: 0</p>
<p>F206 Range for secondary speed ref. „Y“ (%)</p>	<p>Range: 0....100 %</p>	<p>Default setting: 100</p>

In case of combined speed control and secondary speed ref. input via **AI1** or **AI2**, parameter **F205** and **F206** determine the relation to the primary reference

Combined speed control – between primary and secondary speed reference

<p>F207 Output frequency as combination between primary ("X") and secondary ("Y") speed reference signal</p>	<p>Selection: 0: X, only primary reference is used 1: X+Y Sum of primary and secondary reference 2: X or Y (terminal input selection) 3: X or X+Y (terminal input selection) 4: X (Fix-frequencies) and Y (analogue) combined 5: X-Y Difference between primary and secondary value 6: $X+Y(F206-50\%) * (\text{value defined in F205})$</p>	<p>Default setting: 0</p>
---	--	----------------------------------

If **F207=1**: X+Y, the sum of both channels is used – it is not allowed to use PID controller output for speed reference signals .

If **F207=3**: X or (X+Y) determine the output frequency, selection via terminal digital input. – is not allowed to use PID controller output is not allowed for speed reference signal.

If **F207=4**: Fix-frequencies are the primary speed source, with priority to the analogue speed reference input for example (F203=4 und F204=1).

If **F207=5**: The difference between both speed reference channels determine the output frequency – PID controller output is not usable.

If **F207=6**: output frequency is set according to $X+(F206-50\%)*F205$ – PID controller output is not allowed

9) Parameter group 200: Inverter control

Combination between different speed reference channels

F204 F203	0 Internal digital set with memory	1 External Analogue input AI1	2 Extern Analogue input AI2	4 Fix-frequency selection	5 PID controller	6 Keypad potentiom.
0 Internal digital set with memory	○	•	•	•	•	○
1 External Analogue input AI1	•	○	•	•	•	○
2 Extern Analogue input AI2	•	•	○	•	•	○
4 Fix-frequency selection	•	•	•	○	•	•
5 Internal digital set without memory	○	•	•	•	•	○
6 Keypad potentiom.	•	•	•	•	•	○
9 PID controller	•	•	•	•	○	○
10 MODBUS	•	•	•	•	•	•

•: Allowed ○: Not allowed

-The automatic cycling frequency control algorithm can not work in any combination with others

Two / Three wire control for START - STOP - DIRECTION:

This control mode overwrites the setting in F200, F201, F202

<p><i>F208</i> Activation special Two / Three wire control</p>	<p>Selection: 0: Deactivated 1: Two-wire, Type 1 (static) 2: Two-wire, Type 2 (static) 3: Three wire, Typ1 (Impulse / pushbutton control – dynamic) 4: Three wire, Typ2 (Impulse / pushbutton control – dynamic) 5: Pulse / pushbutton control (dynamic)</p>	<p>Default setting: 0</p>
--	---	----------------------------------

F208=0: If Fixed-frequency control is required this mode must be deactivated!

If **F208>0:** functions **F200**, **F201** and **F202** are ignored.

“FWD”, “REV” and “X” are digital terminal input signals for two / three wire control mode. This logical signals are assigned to DI1.....DI6 (DI8) through parameters F316....F323

Assigning-code for DIxx: **FWD=15**, **REV=16**, **X=17** – see chapter: *Parameter group 300 – Digital I/O configuration*

F208=1: Two wire Type 1

K1=START forward (default on DI3)

K2=START reverse (default on DI4)

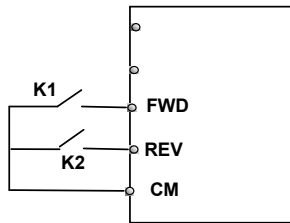

Truth table

K1	K2	
0	0	Stop
1	0	forward
0	1	reverse
1	1	Stop

F208=2: Two wire Type 2

K1=START (default on DI3)

K2=Rotating direction (default on DI4)

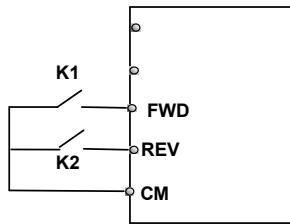

Truth table

K1	K2	
0	0	Stop
0	1	Stop
1	0	forward
1	1	reverse

F208=3: Three wire Typ 1

F208=4: Three wire Typ 2

Pulse/pushbutton control:

FWD(SB2)=START-impulse forward
FWD=NO

REV(SB1)=START-impulse reverse
REW=NO

X(SB3)=cancel impulse (STOP)
X=NC

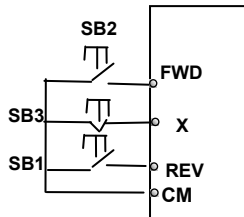

Pulse/pushbutton control:

FWD(SB1)=START-impulse
FWD=NO

X(SB2)=cancel-impulse (STOP)
X=NC

K1=Direction

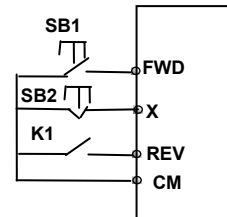

F208=5: Three wire Typ 3

Pulse/pushbutton control:

FWD (SB1) Impulse: START-forward / STOP
 Toggle function
FWD=NO

REV (SB2) Impulse: START-reverse / STOP
 Toggle function
REV=NO

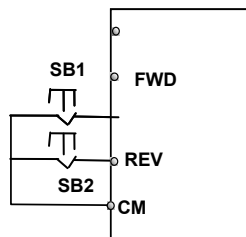

9) Parameter group 200: Inverter control

F209 "STOP" mode selection	Selection: 0: STOP controlled by deceleration ramp 1: Free-stop (uncontrolled) 2: STOP with DC injection	Default setting: 0
-----------------------------------	---	---------------------------

If **F208=1**: STOP command disables the final stage, motor stops uncontrolled by inertia

If **F208=2**: STOP with DC brake function (defined in **F600, F603, F605, F656**)

ATTENTION: In DC brake mode all kinetic energy will dissipate in the rotor, therefore no cyclic use is allowed, to prevent motor from overheating

F210 Frequency resolution with motorpotentiometer control via keypad/terminals	Range: 0.01 - 2.00 Hz	Default setting: 0.01 Hz
---	------------------------------	---------------------------------

F211 Variation speed in motorpotentiometer control mode via keypad/terminals	Range: 0.01 - 100.0 Hz/sec.	Default setting: 5.00 Hz/sec
---	------------------------------------	-------------------------------------

If **F203=0/5**: Inverter starts with initial frequency **F113** (memory with **F203=0**) – **F220=1**, to memorize with power-down too

F212 Status memory with (208=3)	Selection: 0: deactivated 1: activated	Default setting: 0
--	--	---------------------------

If activated, after power down or reset, the inverter will restart with the same status, as before (the previous start impulse forward/reverse was memorized)

F213 Autostart after power-down	Selection: 0: deactivated 1: activated	Default setting: 0
F214 Inverter-Error AUTO-RESET	Selection: 0: deactivated 1: activated	Default setting: 0
F215 Power-on Autostart delay (sec.)	Bereich: 0.1...3000.0 sec.	Default setting: 60.0

F213=1 will force the inverter to restart automatically in case of power off. On power-on, the inverter will restart with the same conditions, as before (frequency/direction). **F215** defines the delay time for power-on autostart. Power-on autostart works only with **F208=0** (dynamic start command)

F214=1 will cause an automatic reset in case of inverter error. **F217** is the delay time for error-reset, while **F215** works as delay time for restart after error-reset.

Autostart is performed only if error occurs during START condition (motor running), in case of STOP condition, only error-reset will be done.

In case of deactivated automatic error-reset, manual reset (keypad/terminal signal) must be done

F216 Number of error-reset tentative	Selection: 0 - 5	Default setting: 0
F217 Delay time for error-reset	Range: 0.0 - 10.0 sec.	Default setting: 3.0 sec.

WARNING: Activation of AUTOSTART and/or AUTORESET may result in unexpected START up of the drive system!!

F219 EEPROM write protection under MODBUS control	Selection: 0: deactivated 1: activated	Default setting: 1
--	--	---------------------------

Please note that **F219**, the EE-prom write protection it is activated by default (to prevent EE-prom from getting destroyed due to repetitive write operations). With this configuration all data sent by MODBUS are stored in the RAM only and get lost after power-down.

If inverter works with continuously varying parameter values, like speed reference, it is recommended, to work in the RAM only.

F220 Memory function for speed and rotation direction in case of power-down	Selection: 0: deactivated 1: activated	Default setting: 0
--	--	---------------------------

Valid in case of internal speed reference (**F113**), (**F155 – F156**)

F224 F-min handling	Selection: 0: f<F-min: STOP 1: f<F-min: RUN with F-min	Default setting: 0
----------------------------	---	---------------------------

F277 Acceleration time 3 (sec.)	Range: 0,1 – 3000sec.	Default setting: depending on inverter size
F278 Deceleration time 3 (sec.)		
F279 Acceleration time 4 (sec.)		
F280 Deceleration time 4 (sec.)		

10) Parameter group 300: Digital I/O configuration

Following digital I/O channels are available on E2000 inverters:

I/O	Inverter size E1-E6 (up to 22 kW)	Inverter size C3-C6 (above 22 kW)
Digital inputs	6 (DI1...DI6)	8 (DI1...DI8)
Digital outputs	1 (DO1) Open Collector 100 mA / 24 V	2 (DO1, DO2) Open Collector 100 mA / 24 V
Relay output	1 Switch over contact 2 A 230V	1 Switchover contact 5 A 230V
Pulse input	DI1 to configure as pulse input	DI1 to configure as pulse input

Hardware-configuration: to perform as described in chapter 5) *Control hardware-configuration of I/O channels*

Parameters **F300-F302** (for outputs) and **F316-F323** (for inputs) allow assignation of various functions to digital I/O channels

Function mapping for digital output channels:

F300 Relais output	Mapping for functions : 0.....43 See table below	Default setting 1 (error)
F301 DO1 Digital output 1		Default setting 14 (Inv. enable)
F302 DO2 Digital output 2		Default setting 5 (START)

Value	Function	Description
0	No function	No function assigned
1	Inverter error	The output is active in case of inverter error
2	Freq. threshold 1	If output frequency reaches the threshold, the output will be activated, threshold, including hysteresis programmable with parameters F307, F308, F309
3	Freq. threshold 2	
4	Inverter disable	Free-STOP command on terminals (system in inertia)
5	Inverter START-1	Inverter in START mode, motor runs, (frequency > 0 Hz)
6	DC Brake	Inverter in DC-Brake mode
7	Rampset 2 selection	Second Accel/Decel. ramp set has been selected
8	Counter final value	Internal counter: The value, set by F314 has been reached
9	Counter intermediate	The counter is in the range, delimited by F315 and F314
10	Inverter overload WARNING	In case of inverter overload, a warning is set, after half the switch off delaytime has passed. Load reduction to cancel, otherwise overload trip (OL1)
11	Motor overload WARNING	Early warning in case of motor overload – similar function as (10) – if no load reduction, overload trip with (OL2) in the display
12	Temp. Ramp stop	Acce./Decel ramp temporarily stopped (Limiting function activated F607...F610)
13	Inverter OK	Inverter is powered on and ready without any error
14	Inverter START - 2	Inverter enabled, similar to 5 but also active with F=0 (final stage enabled)
15	Target freq. reached	Acce./Decel. ramp finished (final freq. reached) (hysteresis to set in F312)
16	WARNING overtemp.	At 80% of the temperature switch-off limit, inverter may trip with (OH) if no cooling
17	Current limit	Inverter has reached the current limit, programmable in F310 and F311
18	Analogue signal interruption	Analogue input signal below the programmable threshold, (see F741/742 and F400/406)
19	Lack of water	Lack of water, detected via motor current (delayed) (see FA26, FA27) – Idling protection
20	Prealarm lack of water	Motor-current fallen below the programmed value (see F754, F755).
21	Modbus-controlled	Output controlled by MODBUS: Set code: 2005H = 1 , Reset code: 2005H=0
22	Modbus-controlled	Output controlled by MODBUS: Set code: 2006H = 1 , Reset code: 2006H=0
23	Modbus-controlled	Output controlled by MODBUS: Set code: 2007H = 1 , Reset code: 2007H=0
24-29	Reserved	
30	Slave-Pump RUN	Pump control modus: The slave pump has been activated
31	Masterpump	Pum control modus: The inverter controlled pump is running
32	Pressure alarm	Pum control modus: The pressure is beyond the limits, set by FA03
42	Reserved	
43	MODBUS Timeout 2	Modbus data not valid (see F907), reset via digital input (60)

10) Parameter group 300: Digital I/O configuration

F303 Configuration DO1 as pulse output	Selection: 0: digital output 1: Pulse output	Default setting 0
---	---	--------------------------

F303=1: Output DO1 is configured as fast pulse signal output, with maximum frequency of 50kHz. Signal configuration through parameter F449 - F453.

Activation and configuration of the "S" shaped ramp

F304 Initial progression	Range: 2.0...50%	Default setting 30%
F305 Final progression		
F306 "S" shaped ramp activation	Selection: 0=Linear ramp 1="S" ramp	Default setting 0

Frequency threshold setting

F307 Frequency threshold 1 (Hz)	Range: F112 - F111 (Hz)	Default setting 10Hz
F308 Frequency threshold 2 (Hz)		Default setting 50Hz
F309 Hysteresis	Range: 0...100%	Default setting 50 %

This are frequency thresholds for signalling through programmable digital outputs - function assignment: **2 / 3**.
Hysteresis to subtract from threshold value

Current threshold

F310 Current threshold (A)	Range: 0...1000 A	Default setting rated current
F311 Hysteresis current thresh.	Range: 0...100%	Default setting 10%

Current threshold, signalled through programmable digital outputs - function assignment: **17**.
Hysteresis to subtract from threshold value

F312 Hysteresis to end-frequency (Hz)	Range: 0.00...5.00 Hz	Default setting 0.00
--	------------------------------	-----------------------------

Valid for the "end of ramp" message through digital outputs – output function assignment: **15**
Hysteresis to subtract from threshold value

Internal counter programming

F313 Divisor for input pulses	Range: 1...65000	Default setting 1
F314 Final counter value	Range: F315...65000	Default setting 1000
F315 Intermediate counter value	Range: 1...F314	Default setting 500

Programmable values, for counter status messaging signals, through digital outputs – functions assigned **8 / 9**
Function **8**: Output pulse is generated, at the counters final value
Function **9**: Output activated after the intermediate value is reached, deactivated at counters final value

Function mapping for digital input channels DI1 – DI6(8)

F316 Function assignment to DI1	Function mapping: 0...61	Default setting 11 (JOG-forward)
F317 Function assignment to DI2		Default setting 9 (EMERGENCY-STDI EXT.)
F318 Function assignment to DI3		Default setting 15 (TERMINAL "FORWARD")
F319 Function assignment to DI4		Default setting 16 (TERMINAL "REVERSE")
F320 Function assignment to DI5		Default setting 7 (RESET)
F321 Function assignment to DI6		Default setting 8 (STDI-DISABLE)
F322 Function assignment to DI7		Default setting 1 (START)
F323 Function assignment to DI8		Default setting 2 (STOP)

Attention: One function can be assigned to one single digital input only (no multiple inputs) If a function is already assigned to a certain input (factory set), the assignment must be deleted (set assignment to 0), before assigning to another input.

Table: Functions of digital inputs

VALUE	Function	DESCRIPTION
0	No function	No function assigned, for unused inputs
1	START function	The input starts the drive system – same as "RUN" on keypad
2	STOP function	Input stops the system – same as "STOP" on keypad
3	Fix-frequency K1	15-Fix-programmed frequencies are selectable (see table below 300-1)
4	Fix-frequency K2	
5	Fix-frequency K3	
6	Fix-frequency K4	
7	RESET	General reset, error reset – same as "STOP/RESET" on keypad
8	STOP-DISABLE	"Free STOP" system stops with inertia (logical inversion: F324)
9	EMERGENCY STOP	Ext. Emerg. STOP signal, ESP on display (signal logic: F325)
10	RAMPSTOP	Inverter holds the actual frequency, independent from other signals (except STOP signal) – ramps are stopped
11	JOG forward	JOG control, see F124, F125 and F126 for parametrizing
12	JOG reverse	
13	Motorpotentiometer	Motorpotentiometer-function, to increase/decrease frequency, (with internal speed reference F203=0 / 5, control parameter: F113, F210, F211).
14	Motorpotentiometer	
15	Terminal "FWD"	Assignment of terminal function "FWD", "REV", and "X" (see two/three wire control – parameter F208)
16	Terminal "REV"	
17	Terminal "X"	
18	BIT1 Ramp set	Selection of Acce./Decel. ramp set (BIT1) – (see table 300-2)
19	Reserved	--
20	M / n	Speed / Torque control mode selection
21	Reference source	Selection of different speed reference sources - combinations (see F207)
22	Counter input	DIxx works as counter input
23	Counter reset	To set the internal counter value to 0
24-29	Reserve	
30	Lack of WATER	IF FA26=1, this input will set the inverter in alarm mode EP1 will show up on the display
31	Water OK	To reset the inverter alarm mode, caused by function 30
32	FIRE pressure	To select "Fire Mode" pressure setpoint (parameter FA58).
33	FIRE MODE	Activation of the "FIRE MODE" (FA59)
34	BIT2 Ramp set	Selection of Accel. / Decel. ramp set (BIT2) – (see table 300-2)
35	Parameterset (BIT1)	Selection of three different parameter-set (BIT1) – (see Tab. 300-3)
36	Parameterset (BIT2)	Selection of three different parameter-set (BIT2) – (see Tab. 300-3)
37	NTC / NO	Motor heath monitoring via NTC / NO contact (KLIXON)
38	PTC / NC	Motor heath monitoring via PTC / NC contact (KLIXON)
49	PID-STOP	Input causes temporary STOP of the internal PID controller
51	Alternative motor	Switch over to alternative motor parameters (FE00=2)
53	Watchdog	Watchdog control-pulse input – if missing, watchdor error occurs
60	RS485 Timeout reset	To reset timeout error signal (dig. output assignment 42)
61	START/STOP	General RUN/STOP signal

Fixed-frequencies selection – table 300-1

K4	K3	K2	K1	Frequency	Programming parameter
6	5	4	3		
0	0	0	0		
0	0	0	1	Fixed-frequency 1	F504/F519/F534/F549/F557/F565
0	0	1	0	Fixed-frequency 2	F505/F520/F535/F550/F558/F566
0	0	1	1	Fixed-frequency 3	F506/F521/F536/F551/F559/F567
0	1	0	0	Fixed-frequency 4	F507/F522/F537/F552/F560/F568
0	1	0	1	Fixed-frequency 5	F508/F523/F538/F553/F561/F569
0	1	1	0	Fixed-frequency 6	F509/F524/F539/F554/F562/F570
0	1	1	1	Fixed-frequency 7	F510/F525/F540/F555/F563/F571
1	0	0	0	Fixed-frequency 8	F511/F526/F541/F556/F564/F572
1	0	0	1	Fixed-frequency 9	F512/F527/F542/F573
1	0	1	0	Fixed-frequency 10	F513/F528/F543/F574
1	0	1	1	Fixed-frequency 11	F514/F529/F544/F575
1	1	0	0	Fixed-frequency 12	F515/F530/F545/F576
1	1	0	1	Fixed-frequency 13	F516/F531/F546/F577
1	1	1	0	Fixed-frequency 14	F517/F532/F547/F578
1	1	1	1	Fixed-frequency 15	F518/F533/F548/F579

Please note: binary selection K1...K4 (F500=1) – for direct selection via K1...K4, use fixed-frequency 1, 2, 4 and 8
Direct selection of only 3 fixed-frequencies: K1....K3 (F500=0)

Accel./Decel. ramp selection - table 300-2

BIT1 Function assignation 18	BIT2 Function assignation 34	Accel./Decel. Ramp-set	Programming parameter
1	0	Ramp set 1	F114 / F115
0	0	Ramp set 2	F116 / F117
1	1	Ramp set 3	F277 / F278
0	1	Ramp set 4	F279 / F280

F324 "STOP - DISABLE" logic selection (8)	Selection: 0=LOW active (NPN) 1=HIGH active (PNP)	Default setting 0
F325 "EMERGENCY -STOP EXTERN" logic (9)		Default setting 0
F326 Watchdog delay time	Range: 0,1...30.000 sec.	Default setting 10,0 sec
F327 Watchdog STOP mode	Selection: 0=free STOP 1=ramp STOP	Default setting 0
F328 Digital input filter factor	Range: 1...100	Default setting 10

Logic inversion of digital inputs:

F340 To invert the digital input logic	0: disabled 1: DI1 inverted 2: DI2 inverted 4: DI3 inverted 8: DI4 inverted 16: DI5 inverted 32: DI6 inverted 64: DI7 inverted 128: DI8 inverted	Default setting: 0
--	--	--------------------

To invert the logic of one digital input. To invert the logic of more inputs, the sum of the single inputs must be stored on this parameter (z.B. DI4 and DI6: 8+32=40)

F300....F339 Diagnostic function	See chapter 19 - Diagnostic
----------------------------------	-----------------------------

11) Parameter group 400: Analogue I/O channel configuration

Two different control boards are used in E2000+ inverters, depending on inverter framesize:

Inverter power-range up to 22 kW - size E1-E6

Inverter power-range 30 – 400 kW - size C3-C6

Both control boards offers independent analogue input/output channels. Each of them can be adapted to various input/output signals – all configuration must be done by software/hardware setting

Details and instruction for hardware setting: see chapter 5) *Control hardware and IO/ channel configuration*

Following instruction describes, how to set software parameters

Configuration of analogue speed reference channels **AI1, AI2, AI3** (A3 = potentiometer on keypad):

F400 Range definition AI1 – lower limit (V)	Range 0.00V...F402	Default setting: 0.00V
F401 Assigment lower limit AI1	Range: 0...F403	Default setting: 1.00
F402 Range definition AI1 – upper limit (V)	Range: F400...10.00V	Default setting: 10.00V
F403 Assigment upper limit AI1	Range: (1.00, F401)...2.00	Default setting: 2.00
F404 Gain factor AI1	Range: 0.0...10.0	Default setting: 1.0
F405 AI1 Filter factor AI1	Range: 0.1...10.0	Default setting: 0.10

The speed range is defined by upper and lower limits, the area in between corresponds to 100% (example: F400=2, F402=8, 2...8V correspond to 0...100%)

Parameter F401 and F403 are used to move the range limits (in %). Rules: 0 = -100%, 1 = 0%, 2 = +100%. (example: F401=0, F403=2 then 100% signal (the range between upper and lower limit) correspond to -100%...+100% reference). In this case 0...10V input signal corresponds to - 50 Hz...0Hz...+50 Hz).

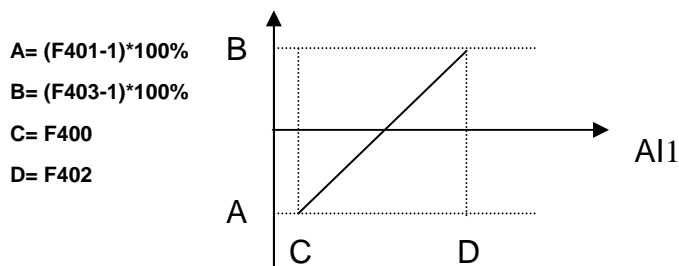

Configuration examples:

Speed reference channel selected: **AI1 - F203=1**,
F-max:F111=50 Hz, **F-min:F112=0Hz**
 All other: default set

Speed reference	Output frequency	F400	F401	F402	F403	F404	Hardware setting
0...10V	0Hz...+50 Hz	0.00V	1.00	10.00V	2.00	1.0	0...10V
0...10V	-50Hz...0Hz...+50Hz	0.00V	0.00	10.00V	2.00	1.0	0...10V
0...10V	-50Hz...0Hz	0.00V	0.00	10.00V	1.00	1.0	0...10V
0...10V	20Hz...50 Hz	0.00V	1.40	10.00V	2.00	1.0	0...10V
-10V...+10V	-50Hz...0Hz...+50 Hz	0.00V	0.00	10.00V	2.00	1.0	+/-...10V
0...20mA	0Hz...50Hz	0.00V	1.00	10.00V	2.00	1.0	0...20mA
4...20mA	0Hz...50Hz	2.00V	1.00	10.00V	2.00	1.0	0...20mA

11) Parameter group 400: Analog I/O configuration

Same configuration for AI2 and AI3 (= keypad potentiometer)

F406 Range definition AI2 – lower limit (V)	Range 0.00V...F402	Default setting: 0.00V
F407 Assignment lower limit AI2	Range: 0...F403	Default setting: 1.00
F408 Range definition AI2 – upper limit (V)	Range: F400...10.00V	Default setting: 10.00V
F409 Assignment upper limit AI2	Range: (1.00, F401)...2.00	Default setting: 2.00
F410 Gainfactor AI2 (%)	Range: 0.0...10.0	Default setting: 1.0
F411 Filter factor AI2	Range: 0.1...10.0	Default setting: 0.10

F412 Range definition AI3 – lower limit (V)	Range 0.00V...F402	Default setting: 0.00V
F413 Assignment lower limit AI3	Range: 0...F403	Default setting: 1.00
F414 Range definition AI3 – upper limit (V)	Range: F400...10.00V	Default setting: 10.00V
F415 Assignment upper limit AI3	Range: (1.00, F401)...2.00	Default setting: 2.00
F416 Gainfactor AI3 (%)	Range: 0.0...10.0	Default setting: 1.0
F417 Filter factor AI3	Range: 0.1...10.0	Default setting: 0.10

F418 0 Hz Dead band 0 Hz AI1	Range: +/- 0...0.50V	Default setting: 0.00
F419 0 Hz Dead band 0 Hz AI2	Range: +/- 0...0.50V	Default setting: 0.00
F420 0 Hz Dead band 0 Hz AI3	Range: +/- 0...0.50V	Default setting: 0.00

0 Hz dead band: If frequency crosses 0Hz range (depending on signal range setting), 0 Hz output frequency will result, within the 0 Hz dead band.

Panel / potentiometer selection (inverter with remote keypad / keypad potentiometer option)

F421 Operating panel	Selection: 1=Integrated panel only 2=Integrated and remote panel	Default setting: 2
F422 Potentiometer	Selection: 0=Integrated panel potentiometer 1=Remote panel potentiometer	Default setting: 0

This configuration can not be reset to factory default (via F160)

F437 Analog filter hysteresis	Range: 1...100	Default setting: 10
-------------------------------	----------------	---------------------

Higher hysteresis value will result in a more stable system, but with longer reaction time on changing speed reference signal

Pulse speed reference signal input configuration:

Configuration is done in the same way, as for analogue speed reference signal. DI1 is predestinated as pulse signal input channel. DI1 selection is done automatically, if pulse reference signal is selected as speed reference source. Maximum input frequency: 50 kHz.

F440 Min. pulse frequency (kHz)	Range: 0.00...F442	Default setting: 0.00 kHz
F441 Assignment min. frequency	Range: 0.00...2.0	Default setting: 1.00
F442 Max. pulse frequency (kHz)	Range: F440...50.00 kHz	Default setting: 10.00 kHz
F443 Assignment min. frequency	Range: Max (1.00, F441) ...2.00	Default setting: 2.00
F445 Filter factor pulse input	Range: 0...100	Default setting: 0
F446 0 Hz dead-band	Range: 0...+/- F442	Default setting: 0.00

- Range configuration and dead band selection will be done in the same way, as for analogue input signals

Non-linear characteristic for analogue channels

A non-linear characteristic can be assigned to analogue input channels **AI1** and **AI2**. Programming is done in sense of the table below

F460 Characteristic AI1	Selection: 0=linear 1=non-linear	Default setting: 0
F461 Characteristic AI2	Selection: 0=linear 1=non-linear	Default setting: 0
F462 input level 1 for AI1	Range: F400 - F464	Default setting: 2.00V
F463 Assignment input level 1 (%)	Range: F401 - F465	Default setting: 1.20
F464 input level 2 for AI1	Range: F462 - F466	Default setting: 5.00V
F465 Assignment input level 2 (%)	Range: F463 - F467	Default setting: 1.50
F466 input level 3 for AI1	Range: F464 - F402	Default setting: 8.00V
F467 Assignment input level 3 (%)	Range: F465 - F403	Default setting: 1.80
F468 input level 1 for AI2	Range: F406 - F470	Default setting: 2.00V
F469 Assignment input level 1 (%)	Range: F407 - F471	Default setting: 1.20
F470 input level 2 for AI2	Range: F468 - F472	Default setting: 5.00V
F471 Assignment input level 2 (%)	Range: F469 - F473	Default setting: 1.50
F472 input level 3 for AI2	Range: F470 - F412	Default setting: 8.00V
F473 Assignment input level 3 (%)	Range: F471 - F413	Default setting: 1.80

Assignment of intermediate points, in the same way as for endpoints

(0= -100%, 1=0%, 2=+100%)

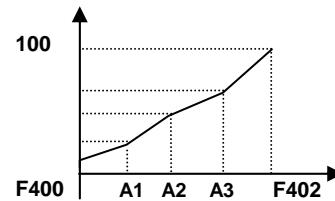

Analogue output configuration AO1, AO2

F423 Signal type configuration output AO1 current/voltage signal	Selection: 0=0...5V 1=0...10V, 0...20mA * 2=4...20mA *	Default setting: 1
F424 Inverter output frequency assigned to minimum output signal on AO1	Range: 0.0...F425	Default setting: 0.05 Hz
F425 Inverter output frequency assigned to maximum output signal on AO1	Range: F424...F111	Default setting: 50.00 Hz
F426 Gain factor AO1	Range: 0...120%	Default setting: 100

*) The DIP-SWITCH U/I must be set, to get current signal on AO 1 output – see chapter 5) *Control hardware and IO/channel configuration*

F427 Signal type configuration output AO2 current signal only	Selection: 0=0...20 mA 1=4...20mA	Default setting: 0
F428 Inverter output frequency assigned to minimum output signal on AO2	Range: 0.0...F429	Default setting: 0.05 Hz
F429 Inverter output frequency assigned to maximum output signal on AO2	Range: F428...F111	Default setting: 50.00 Hz
F430 Gain factor AO2	Range: 0...120%	Default setting: 100

F431 Assignment of operating parameters to AO1	Selection: 0=Motor frequency 1=Motor-current normalized on 2xI-n 2=Motor-voltage (normalized on 230/400V) 3=A11 4=A12 5=Impulse input 6=Torque – normalized to m-n 7=Set via MODBUS 8=Target frequency 9=Calculated speed 10=Torque (motoric)	Default setting: 0
F432 Assignment of operating parameters to AO2		Default setting: 1

Assignment motor current: The full range corresponds to 0...2x inverter rated current

Assignment motor voltage: The full range corresponds to the inverter rated voltage (230V/400V)

F433 Multiplier for motor voltage meter	Range: 0.01...5* rated value	Default setting: 2.0
F434 Multiplier for motor current meter		Default setting: 2.0
F437 Filter factor analogue output	Range: 1...100	Default setting: 10

Pulse output DO1:

Digital output terminal DO1 can be programmed via F303 as pulse signal output – configuration is made in a similar way, as for analogue outputs

F449 Max. frequency pulse output DO1	Range: 0.00...50.00 kHz	Default: 10.00 kHz
F450 0-point offset (%)	Range: 0.0...100.0 %	Default: 0.0%
F451 Multiplier	Range: 0.00...10.00	Default: 1.00
F453 Assignment of operating parameters to DO1	Selection: 0=Motor frequency 1=Motor-current normalized on 2xI-n 2=Motor-voltage (normalized 230/400V) 3=A11 4=A12 5=Impulse input 6=Torque – normalized to m-n 7=Set via MODBUS 8=Target frequency 9=Calculated speed 10=Torque (motoric)	Default setting: 0

12) Parameter group 500: Fixed-frequency, automatic cycling frequencies

Up to 15 fixed-frequencies are selectable on E2000+ inverters, including individual ramp and direction setting. Automatic cycling sequence for up to 8 fixed-frequencies can be set, including ramp, direction, run- and pausing time.

Set parameter **F203=4 (F204=4)**, to select fixed frequency mode:

F500 Fixed-frequency mode selection	Selection: 0: 3 Fixed frequencies are available 1: 15 Fixed frequencies available, binary coded (K1, K2, K3, K4 - terminal) 2: Up to 8 Fixed frequencies – auto-cycling mode	Default: 1
--	---	------------

F500=0: Up to 3 fixed frequencies, direct selection via terminal, to combine with analogue setpoint, fixed freq. have priority

F500=1: Up to 15 fixed freq. binary selection, to combine with analogue setpoint, fixed freq. have priority

F500=2: Up to 8 fix. freq. in AUTOCYCLING mode

RUN/STOP control in fix.freq. mode: If (F208=0) via keypad, or via dig input, function assignment: **61**.

alternative: F208=1/2, FWD/REV mapping for dig. input required

F203	F500	Fixed frequency mode	Description
4	0	3 Fixed frequencies direct selection	To combine with analogue control, fixed-frequencies have priority
4	1	15 Fixed frequencies binary selection	To combine with analogue control, fixed-frequencies have priority
4	2	Up to 8 auto-cycling fixed frequencies	Independent mode, no manual frequency control is possible during cycle, except STOP command – F501, F502, F503 are the auto-cycling parameters

Auto-cycling parameter:

F501 Number of different frequencies for auto-cycling function	Selection: 2...8	Default setting: 7
F502 Number of automatic cycles	Range: 0....9999 0 = Endless cycling	Default setting: 0
F503 Status after cycle completed	Selection: 0: Stop 1: Keep last valid frequency	Default setting: 0

Programming of the individual fixed-frequencies:

	Acceleration ramp fixed-frequencies 1 - 15 (0,1...3000sec.)	Deceleration ramp fixed-frequencies 1 - 15 (0,1...3000sec.)	Rotation fixed-frequencies 1 - 15 – (0=FWD, 1=REV)	Auto-cycle - duration for fixed-frequencies 1 - 8 (0,1...3000sec.)	Auto-cycle – pausing time for fixed-frequencies 1 - 8 (0,1...3000sec.)	
F504 Fixed-frequency 1 (Hz)	F519	F534	F549	F557	F565	Default setting: Accel./Decel. time, depending on inverter model 0.2 - 4.0KW: 5.0 sec. 5.5 - 30KW: 30.0 sec. >30kW: 60 sec. Range for F504 – F518: F112F 111 Default: 5.00Hz Default: 10.00Hz Default: 15.00Hz Default: 20.00Hz Default: 25.00Hz Default: 30.00Hz Default: 35.00Hz Default: 40.00Hz Default: 5.00Hz Default: 10.00Hz Default: 15.00Hz Default: 20.00Hz Default: 25.00Hz Default: 30.00Hz Default: 35.00Hz
F505 Fixed-frequency 2 (Hz)	F520	F535	F550	F558	F566	
F506 Fixed-frequency 3 (Hz)	F521	F536	F551	F559	F567	
F507 Fixed-frequency 4 (Hz)	F522	F537	F552	F560	F568	
F508 Fixed-frequency 5 (Hz)	F523	F538	F553	F561	F569	
F509 Fixed-frequency 6 (Hz)	F524	F539	F554	F562	F570	
F510 Fixed-frequency 7 (Hz)	F525	F540	F555	F563	F571	
F511 Fixed-frequency 8 (Hz)	F526	F541	F556	F564	F572	
F512 Fixed-frequency 9 (Hz)	F527	F542	F573			
F513 Fixed-frequency 10 (Hz)	F528	F543	F574			
F514 Fixed-frequency 11 (Hz)	F529	F544	F575			
F515 Fixed-frequency 12 (Hz)	F530	F545	F576			
F516 Fixed-frequency 13 (Hz)	F532	F546	F577			
F517 Fixed-frequency 14 (Hz)	F532	F547	F578			
F518 Fixed-frequency 15 (Hz)	F533	F548	F579			

Warning: Function REV (assignment **16**) with F208=2 inverts rotation

13) Parameter group 600: DC-Brake control / Aux. functions

DC-Brake function parameters:

F600 DC-Brake function activation	Selection: 0: DC-Brake deactivated 1: DC injection before START 2: DC injection after STOP 3: Before START and after STOP	Default setting 0
F601 Frequency threshold for DC-injection	Range: 0.2...5.0 Hz	Default setting 1.00 Hz
F602 Intensity DC-Brake START	Range: 0...100%	Default setting 10
F603 Intensity DC-Brake STOP		
F604 DC-Brake duration START	Range: 0.0 - 10.0 sec.	Default setting 0.5 sec.
F605 DC-Brake duration STOP		

DC Brake can be used as an alternative to STOP controlled by ramp (F209=2). Intensity is controlled by (F603), duration by (F605).



Attention!! Improperly programmed DC-Brake function may result in inverter overcurrent trip and/or motor overheating

In case of braking by DC injection all kinetic energy will be dissipated in the motor rotor. Repeatedly use of the DC brake function may result in motor overheating

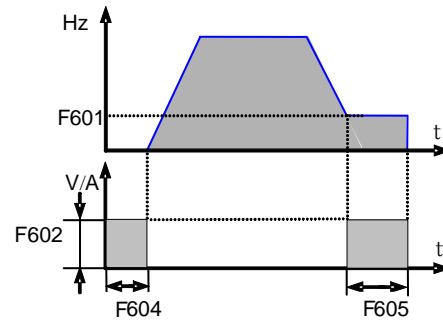

Message "DC-Brake active" may be configured through digital output – assignation code 6

Current- Voltage limiting functions

Limiting functions for current and voltage are available in standard E2000 inverters

Current limiting function: To program a motor current threshold. If motor current reaches the threshold (F608) during acceleration, the acceleration ramp will delay, until current drops below the limit. If current exceed the limit at target frequency (ramp completed), the frequency will be reduced, if necessary, down to the minimum frequency.
Current limiting function is always deactivated during deceleration ramp.

Voltage limiting function: To limit the DC-link voltage increase, due to energy regeneration during deceleration phase. If voltage reaches the limit (F609), the limiting function will stretch the deceleration ramp.

The limiting status of the inverter can be signaled through any programmable digital output. Function assignation code: 12

F607 Activation limiting functions	Selection: 0..2: reserved 3: current/voltage 4: voltage 5: current	Default setting: 3
F608 Current limit (% rated current)	Range: 60...200 %	Default setting: 160 %
F609 DC voltage limit (% rated voltage)	Range: 60...200 %	Default setting: 140 %
F610 Max. duration if limiting status (sec.)	Bereich: 0.1...3000.0 sec.	Default setting: 5.0 sec.

If limiting status of the inverter takes longer than time, set in F610, the system will stop, signaled by OL1 on the display

Brake Chopper control (internal brake chopper)

F611 Brake chopper activation Threshold (V)	Range: 200...1000 V DC	Default setting: 400V inverter: 770V DC 230V inverter: 380 V DC
F612 Max. duty-cycle chopper	Range: 0...100 %	Default setting: 80 %

"Catch on the fly" function: To get already spinning motor controlled (V/Hz mode only)

F613 Activation of the function	Selection: 0: Function deactivated 1: Always active 2: Active after POWER_ON	Default setting: 0
F614 Scan process starting from:	Selection: 0: Last memorized frequency 1: Starting from 0 Hz 2: Starting from F-max.	Default setting: 0
F615 Scan speed	Range: 1...100	Default setting: 20
F627 Current limiting	Range: 50...200%	Default: 100 %

DC-voltage control

F631 DC-voltage control setting	Selection: 0: Active 1: Deactivated	Default setting: 0
F632 Nominal voltage for DC-control	Range: 200...800 V	Default: 380V DC / 700V DC
F633 DC-control frequency adaption band (Hz)	Range: 0,01...10 Hz	Default: 5,00 Hz

IF **F631=1**: The inverter will try to keep DC-voltage constant for different regenerating load conditions (during deceleration ramp or in case of motor generator function). Reduction of braking torque, or frequency adaption

Attenuation function to prevent from torque oscillation (motor vibration at low frequencies)

F641 Anti-oscillation-function activation (for inverters <SIZE 7 only)	Selection: 0: deactivated 1: activated	Default setting: 0
---	---	--------------------

It works in V/Hz mode only (**F137=0,1,2**), "Catch on the fly" function to deactivate (**F613=0**)
PWM mode to set on "RANDOM" (**F159=1**)

Power drop compensation

F657 Activation of the power drop compensating function	Selection: 0: deactivated 1: activated	Default setting: 0
F658 Compensation ramp: Accel.	Range: 0,0.....3000sec. – 0,0=F114	Default setting: 0,0 sec
F659 Compensation ramp: Decel.	Range: 0,0.....3000sec. – 0,0=F115	Default setting: 95
F660 Voltage threshold to start compensation function	Range: 230V Inverter: 215V.....F661 400V Inverter: 400V.....F661	Default: 230V Inverter: 250V 400V Inverter: 450V
F661 Voltage threshold to stop compensation function	Range: 230V Inverter: F660.....300V 400V Inverter: F660.....530V	Default: 230V Inverter: 270V 400V Inverter: 480V

In case if power drop (short interruptions), the inverter try to compensate the DC voltage. If the voltage falls below the threshold, programmed in **F660**, the inverter try to keep the DC voltage constant, performing controlled deceleration (inertial energy feed back). If DC voltage reaches the value in **F661**, the inverter will continue with normal operation, heading to the target frequency. Accel./Decel. ramp, programmed in **F658** and **F659** are in function during the compensation process.

Independent motorvoltage control via separate setpoint

For special applications, the motor voltage may be controlled independently from output frequency (F137=4)

F671 Source for voltage setpoint	Selection: 0: Intern - F672 1: AI1 2: AI2 3: Reserved 4: MODBUS - 2009H 5: Pulse input 6: PID 7...10: Reserviert	Default setting: 0
F672 Internal voltage setpoint	Range: 0,0.....100%	Default setting: 100%
F673 Lower limit motor voltage (%)	0%...F674	Default setting : 0%
F674 Upper limit motor voltage (%)	F673...100%	Default setting : 100%
F676 Voltage rise timet (sec.)	0.0....3000	Default setting : 5.0
F676 Voltage drop time (sec.)	0.0....3000	Default setting : 5.0
F677 STOP mode for independent motor voltage control	Selection: 0: Voltage and frequency drop simultaneously 1: Voltage drops first 2: Frequency drops first	Default setting: 0

14) Parameter group 700: Error handling and protection functions

Error codes **ON DISPLAY** (error memory code)

CODE	Description	Reason	Remedy
OC (2)	Over-current – hardware detected	Too short ramps, short circuit on output motor defect, system blocked, wrong motor parameter setting	Increase Accel/Decel ramp time Check cabling / motor Check mechanical system Reduce BOOST Check motor parameter setting
OC1 (16)	Over-current – software detected		
OC2 (67)	Over current – software detected		
GP (26)	Ground protection error	Short circuit to ground	Check cable / motor
OL1 (5)	Inverter overload	Overload	Reduce load
OL2 (8)	Motor overload	Overload	Check for right dimensioning
OE (3)	DC-link over-voltage	Input power over-voltage Too high inertia Deceleration ramp too short Improper PID controller parameter	Check for correct supply voltage Inverter rated voltage correct?? Use larger brake resistors Increase deceleration time
PF1 (4)	Input phase-loss	One input-phase missing	Check power supply
PF0 (17)	Phase-unbalance output	Motor-phase / cabling interrupted	Check cabling / check motor
LU (6)	Undervoltage	Voltage on DC_Link too low	Check power supply
OH (7)	Inverter overheat	Environment temperature too high Poor cabinet heat-exchange Inverter / heatsink polluted PWM frequency too high Motor cable too long	Check for environment / working conditions Insert all parameters correctly Check for correct inverter mounting
OH1 (35)	Motor overheat	Motor PTC signal triggered	
AErr (18)	Analogue signal interruption	The analogue signal value is below the lower limit, programmed in F4xx parameters	Inspect control cabling Insert correct parameters for analogue signal lower limit Measure reference signal source
EP (20) EP2 (20) EP3 (19)	Inverter under-load / idling	Idling Lack of water Mechanical system broken	Check mechanical drive system Reestablish water supply
nP (22)	Pump control: Pressure beyond limits	Pressure beyond limits Inverter in SLEEP mode	Insert correct pump controller parameters – open water flow
CE (45)	MODBUS time-out	MODBUS signal missing	Check MODBUS cabling / source – MODBUS parameter setting
ESP (11)	External emergency	The external emergency signal has been triggered	
ERR0	Parametrizing error	Parameter change not accepted	Stop inverter for parameter setting
ERR1	Wrong password	No or wrong password input Parameter change not allowed	Insert correct password
ERR2 (13)	Autotuning error	Motor can not free rotate during dynamic testing cycle	Separate motor from drive system
ERR3 (12)	Overcurrent in STOP condition	Hardware failure	Visual inspection of internal cabling Contact EURA service-center
ERR4 (15)	Current sensor error	No current signal on control board	Visual check of internal cabling, contact EURA service-center
ERR5 (23)	PID ERROR	PID controller error, due to improper PID parameter	Set PID parameter correctly
ERR6 (49)	Watchdog Timeout	Timeout caused by missing watchdog signal	Check signal on dig. input - assign digital input to watchdog function
EEP (47)	EEPROM error	EEPROM write/read error	Replace control board

Inverter general fault message through digital output:

Function assignation code **1**: Inverter error message

Function assignation code **13**: Inverter OK message

14) Parameter group 700: Error handling and protection functions

Programmable delay for STOP- DISABLE with STOP signal through terminal

F700 Delay selection	Selection: 0: immediate STOP/DISABLE 1: with delay	Default setting: 0
F701 Delay time setting (sec.)	Range: 0.0...60.0 sec.	Default setting: 0.0 sec.

only for signal through terminal (digital input) (F201=1/2/4, F209=1)

Fan control mode

F702 Fan control mode setting	Selection: 0: temperature-controlled 1: ON with inverter on power 2: ON with inverter in START mode	Default setting: 2
--------------------------------------	---	--------------------

F702=0: Temperature controlled, fan switch on, after temperature reaches the threshold, set in **F703**.

F702=2: Fan is switched on as long, as inverter in START mode, after STOP command, fan-runtime is extended, until heatsink temperature falls below 35°C.

Single phase inverter, framesize **E1** do not have fan control mode selection, fan is always ON, when inverter on power supply

F703 Fan control temperature threshold (C°)	Read Only	Factory set: 35C°
--	-----------	-------------------

Inverter/Motor over-load protection

Free programmable threshold values for warningsignal before inverter/motor overload fault.

Digital outputs, to program for warning messages (function mapping code **10 / 11**)

F704 Threshold for warning INVERTER OVERLOAD (%) 10	Range: 50 - 100%	Werk: 80 %
F705 Threshold for warning MOTOR OVERLOAD (%) 11	Range: 50 - 100%	Werk: 80 %
F706 Threshold for INVERTER overload trip (%)	Range: 120 - 190%	Werk: 150 %
F707 Threshold for motor overload trip (%)	Range: 20 - 100%	Werk: 100 %

% values refer to relative motor / inverter rated values

All warnings are delayed, depending on overload grade

Warning for motor overload depends on working frequency too

Following graphics, to show warning delay characteristic:

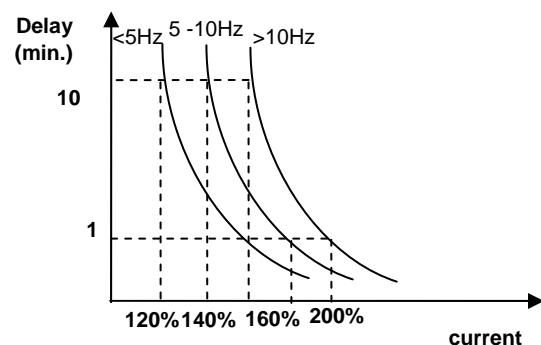
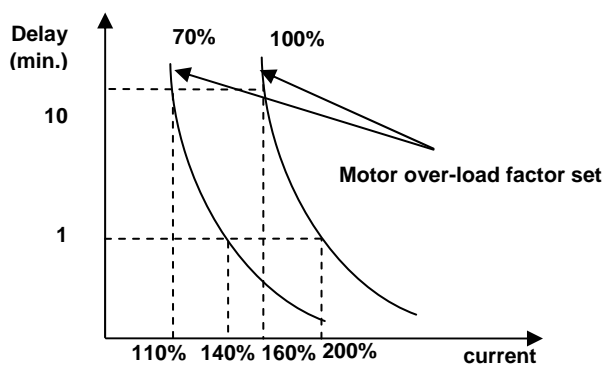

Fault history

Read only:

F708 Last fault	Fault codes: See page 56	F711 Frequency at last fault (Hz) F712 Current at last fault (A) F713 DC-Link voltage at last fault (V)
F709 Fault last but one		F714 Frequency at fault last but one (Hz) F715 Current at fault last but one (A) F716 DC-Link voltage at fault last but one (V)
F710 Fault last but two		F717 Fault last but two (Hz) F718 Current at fault last but two (A) F719 DC-Link voltage at fault last but two (V)

Error event counters:

F720 Overcurrent	OC	
F721 Overvoltage	OE	
F722 Overtemperature	OH	
F723 Overload	OL1	

Protection functions – configuration

Activation of phase-loss, under-voltage and temperature monitoring

<i>F724</i> Input phase-loss monitoring	Selection: 0: deactivated 1: activated	Default setting: 1 (T2/T3 models)
<i>F725</i> Under-voltage reset	Selection: 1: manual reset 2: autoreset	Default setting: 2
<i>F726</i> Over-temperature monitoring	Selection: 0: deactivated 1: activated	Default setting: 1
<i>F727</i> Output phase-loss monitoring	Selection: 0: deactivated 1: activated	Default setting: 1

Delay for inverter error trip

<i>F728</i> Delay phase-loss detection (sec.)	Range: 0.1 - 60.0 sec.	Default setting: 0.5 sec.
<i>F729</i> Delay for under-voltage detection (sec.)	Range: 0.1 - 60.0 sec.	Default setting: 5.0 sec.
<i>F730</i> Delay for over-temperature detection (sec.)	Range: 0.1 - 60.0 sec.	Default setting: 5.0 sec.
<i>F732</i> Threshold for under-voltage detection (V) (DC-Link voltage)	Range: 0.1 – 450V	230V inverter: 215 V 400V inverter: 400 V

Overcurrent detection via software **OC1**

<i>F737</i> Software controlled overcurrent detection	Selection: 0: deactivated 1: activated	Default setting: 0
<i>F738</i> Software current limit (rated current unit)	Range: 0.50 - 3.00	Default setting: 2.5
F739 SW over-current inverter-trip counter OC1		

14) Parameter group 700: Error handling and protection functions

Analogue signal interruption detection

F741 Analogue signal interruption – fault handling mode	Selection 0: deactivated 1: STOP and AErr on display 2: STOP without any message on display 3: Inverter continue running with f-min 4: Reserved	Default setting: 0
F742 Threshold for detection (%)	Range: 1...100 %	Default setting: 50%

Message via digital output (function code 18)

If **F400** / **F406** set lower than 0.01V interruption detection is deactivated (a minimal value of 1V is recommended)

Detection threshold is referred to lower limits for analogue input signals, set in parameters **F400** / **F406**

Overheat warning level

F745 Warning threshold (%)	Range: 0...100%	Default setting: 80
F747 Temperature depending carrier frequency adaption	Selection: 0: deactivated 1: activated	Default setting: 1

Heatsink over-temperature warning (message via digital output (function code 16))

All referred to 95°C, the inverter trip temperature

With temperature depending PWM frequency-adaption activated (**F747=1**), inverter will start to decrease PWM frequency gradually, at heatsink temperature of 86°C

If PWM frequency is configured for "RANDOM" (**F159=1**), temperature depending PWM adaption is always deactivated

Motor overload coefficient

F752 Motor overload integration coefficient	Range: 0,1...20%	Default setting: 1.0
F753 Motor type definition	Selection: 0: Standard motor 1: Forced cooled inverter motor	Default setting: 1

For **F753=0**, motor protection threshold will be lowered for frequencies below 30 Hz

Idling detection

F754 Idling current threshold (%)	Range: 0...200 %	Default setting: 5%
F755 Delay time for idling detection (sec.)	Range: 0...60 sec.	Default setting: 0.5 sec.

Message via digital output (function code 20)

Ground protection

F760 Ground short monitoring	Selection 0: disable 1: enable	Default setting: 1
-------------------------------------	---	--------------------

Reversing mode setting

F761 Reversing mode (F=0 / F-START)	Selection 0: through F=0 1: through F-start (F109)	Default setting: 0
--	---	--------------------

F761=0: Reversing goes through f=0 (with deathtime **F120**)

F761=1: Reversing goes through f=Start (**F109**), (without deathtime **F120**)

15) Parameter group 800: Autotuning – Motor data programming

Attention: All motor data must be programmed exactly, as reported on motor nameplate. Especially for SENSORLESS VECTOR OPERATION, precise motor data entry is mandatory, to guarantee reliable function of the drive

<i>F800</i> Automatic motor-data measurement (AUTOTUNING)	Selection: 0: AUTOTUNING deactivated 1: START dynamic AUTOTUNING 2: START static AUTOTUNING	Default setting: 0
<i>F801</i> Motor-rated power (kW)	Range: 0.2...1000 kW	
<i>F802</i> Motor-rated voltage (V)	Range: 1...440 V	
<i>F803</i> Motor-rated current (A)	Range: 0.1...6500 A	
<i>F804</i> Number of poles (p) (read only!!)	Automatically calculated	
<i>F805</i> Rated speed (rpm)	Range: 1...30000 U/min	
<i>F810</i> Motor-rated frequency (Hz)	Range: 1.0...300.0 Hz	Default setting: 50.00Hz

After correct input of the data, reported on the the table above, intelligent AUTOTUNING functions can be used, to measure, and memorize all unknown motor data.

AUTOTUNING mode:

F800=0: No AUTOTUNING, after parameter F801...F803, F805 and F810 are set, standard values are chosen for remaining parameters

F800=1: Dynamic AUTOTUNING – motor without load. After input of motor nameplate data in **F801...F805** and **F810**, the process can be started in the following way:

Set F800=1, press  key; The automatic process starts now, „TEST“ shown on display, after a few seconds, the motor will accelerate and decelerate, with ramps, programmed in F114 and F115. After completion of the cycle, all motor data will be stored, and F800 will reset to 0

F800=2: Static AUTOTUNING, if there is no way to separate the motor from the load, static data measurement is available – the motor will not rotate during the cycle, and it is not allowed, to rotate it. Following, to start the static cycle:

Set F800=2, press  key; The automatic process starts, „TEST“ shown on display, after a few seconds it will terminate; All values for rotor resistance main inductivity and leakage inductivity are stored automatically on parameters F806 to F808, F800 will reset to 0.

Autotuning results for ASYNCRONUS motors

<i>F806</i> Stator resistance (Ohm)	Range: 0.001...65.00 Ohm	
<i>F807</i> Rotor resistance (Ohm)	Range: 0.001...65.00 Ohm	
<i>F808</i> Leakage inductivity (mH)	Range: 0.01...650.0 mH	
<i>F809</i> Main inductivity (mH)	Range: 0.1...6500 mH	

If parameter **F801** (Motor rated power) is changed, all parameters **F806...F809** are reset to default values, a following AUTOTUNING process, as described above may be used for fine tuning.

Sensorless Vector speed controller parameter (ASYNCRONUS motor only)

F812 Start excitation time (sec.)	Range: 0...30.0 sec.	Default setting: 0.3
F813 Proportional gain in frequency range 1 KP1	Range: 1...100	Default setting: 30
F814 Integration time in frequency range 1 KI1	Range: 0.01...10.00	Default setting: 0.5
F815 Proportional gain in frequency range 2 KP2	Range: 1...100	Default setting: Depending on inv. model
F816 Integration time in frequency range 2 KI2	Range: 0.01...10.00	Default setting: 1.00
F817 Range 1 end frequency	Range: 0...F111	Default setting: 5.00 Hz
F818 Range 2 start frequency	Range: F817...F111	Default setting: 50.00 Hz
F819 Controller precision	Range: 50...200	Default setting: 100
F820 Speed loop filter constant	Range: 0...100	Default setting: 0
F827 Controller scan-rate	Range: 10.00...4000	Default setting: 40.00
F844 Idle current (A)	Range: 0,1 A...F803	Default setting: depending on size

F817, F818: Parameter for frequency depending PID parameter selection



ATTENTION!! Improper setting of speed regulating parameters may result in system instability. This may cause malfunction of the machine and / or damage of mechanical parts

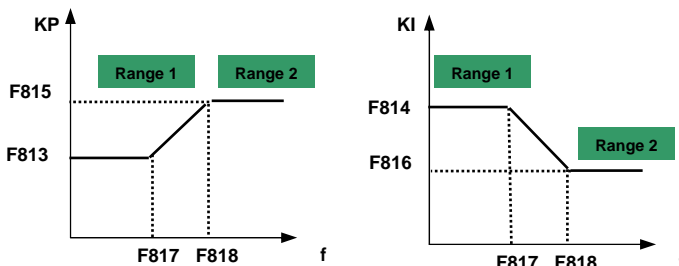

It is recommended to keep factory default parameters, slight modification, to optimize the system must be done with caution.

Parameter for permanent magnet synchronous motor control

(F106=6) PMM control algorithm selected

After input of basic motor parameters (F801...F810), AUTOTUNING procedure as described above can be used to measure following parameters:

F870 Motor feed back electrical force	V/1000 rpm	
F871 Induktivity D-axis (Ohm)		
F872 Induktivity Q-axis (Ohm)		
F873 Stator resistance (Ohm/Phase)		
F876 Idling current (% rated current)		Default setting 20%
F877 Frequency compensation idle current (%)		Default setting 0%
F878 Threshold idle current compensation (Hz)		Default setting 10Hz%
F880 Scan-rate controller		Default setting 0,2 sec.

16) Parametergroup 900: RS485 hardware and interface parameters

Please refer on specific MODBUS manual, for protocol, control algorithm, control registers, and other details

F900 Inverter address	Selection: 1...255: fixed addresses 0: address set via BUS	Default setting: 1
F901 RS485 operation mode	Selection: 1: ASCII protocol 2: RTU protocol	Default setting: 2
F902 Number of STOP bit	Selection: 1 - 2	Default setting: 2
F903 Parity check	Selection 0: no check 1: ODD parity 2: EVEN parity	Default setting: 0
F904 Baudrate	Selection: 0: 1200 1: 2400 2: 4800 3: 9600 4: 19200 5: 8400 6: 57600	Default setting: 3
F905 MODBUS Time-out	Range: 0.0.....3000 sec.	Default: 0.0 sec
F907 M-BUS Time-out warning	Range: 0.0.....3000 sec.	Default: 0.0 sec

F905: MODBUS time-out, in case of missing MODBUS command within the timeframe, set in **F905** inverter will STOP for safety reason and **CE** will appear on the display. For **F905=0**, the safety function is disabled.

F907: MODBUS time-out warning. If **F907>0**, and MODBUS signal is missing for the time, set by **F907**, the inverter will send an error warning trough a programmable digital output (mapping code **43**). This signal may be reset via digital input (mapping code **60**).

Hardware MODBUS - interface :

All EURA Drives inverter are equipped with a unique RS485 connector. This port is used for inverter control via MODBUS and for parametrizing the inverter, using PC software or COPY STICK.

The picture below shows the pin-out of the 4 pole connector

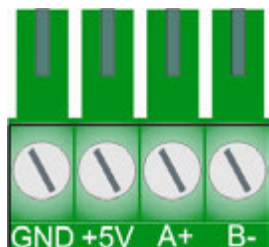

An auxiliary power supply, based on microprocessor ground delivers 50 mA / 5V

Inverter up to 22 kW Size E1 - E6:

The interface connector is located on the left side of the inverter

Inverter 30 kW and above Size C3 – C6:

The interface connector is located on the controlboard inside the drive

17) Parameter group A00: PID controller parameter

Integrated PID-controller

An integrated PID-controller is available on standard E2000+ inverters. It is suitable for simple closed loop control projects. Specific pump control algorithm allow constant pressure control of single pumps and dual pump booster stations. Cascade control and master slave control with automatic interchange functions are available as well

FA00 Controller configuration	Selection: 0: closed loop control – single pump control 1: Master/Slave Mode 2: Master/Slave with interchange	Default setting: 0
--------------------------------------	---	--------------------

FA00=0: Suitable for standard closed loop control projects (single pump pressure control).

FA00=1: Dual pump cascade mode control, master pump with variable speed, slave pump fixed speed (direct grid connected)

FA00=2: Dual pump cascade mode control, master pump with variable speed, slave pump fixed speed (direct grid connected), including master - slave interchange, (time set by **(FA25)**)

Controller configuration for set-point and feed-back channel (see graphic on following page)

FA01 PID set-point channel	Selection: 0: internal reference (value in FA04) 1: Analogue input AI1 2: Analogue input AI2 3: AI3 (Potentiometer on keypad) 4: Frequency (pulse input)	Default setting: 0
-----------------------------------	--	--------------------

FA02 PID feed-back channel	Selection: 1: Analogue input AI1 2: Analogue input AI2 3: Frequency (pulse input) 4: Reserved 5: Motor current 6: Output power 7: Output torque	Default setting: 1
-----------------------------------	---	--------------------

FA03 Upper controller limit (% of set-point)	Range: 0.0...100.0 %	Default setting: 100.0
FA04 Internal set-point value (%)	Range: FA05....FA03 %	Default setting: 50.0
FA05 Lower controller limit (% of set-point)	Range: 0.0...100.0%	Default setting: 0.0

If the controller works beyond the limits in **FA03** - **FA05** inverter will be disabled and **(nP)** on display

FA06 PID controller polarity	Selection: 0: Positive 1: Negative	Default setting: 1
-------------------------------------	---------------------------------------	--------------------

FA07 Automatic sleep mode	Selection: 0: activated 1: deactivated	Default setting: 1
FA09 Frequency threshold for sleep mode activation	Range: between F112...F111	Default setting: 5.00 Hz
FA10 Time delay for sleep mode activation (sec.)	Range: 0...500 sec.	Default setting: 15 sec.
FA11 Delay-time for restart from sleep mode	Range: 0...3000 sec.	Default setting: 3.0 sec

If the inverter runs for a programmed time, (set by **FA10**) below the minimum frequency, (set by **FA09**), it will stop and enter in sleep mode, displayed as **nP**. (feed-back value must stay within programmed limits FA03-FA04).

If feed back (pressure) falls below the value in **(FA05)**, inverter will restart again, after the delay-time in **(FA11)**

FA12 Maximum working frequency in PID	Range: FA09....Fa111 (Hz)	Default setting: 50 Hz
--	---------------------------	------------------------

This parameter limits the maximum working frequency in PID mode

FA18 Variable set-point allowed	Selection: 0: deactivated 1: activated	Default setting: 1
--	---	--------------------

If **FA18=0:** It is not possible, to change the fixed set-point in **(FA04)** during controller operation

17) Parameter group A00: PID controller setup

E2000 - CONTROLLER BLOC DIAGRAM

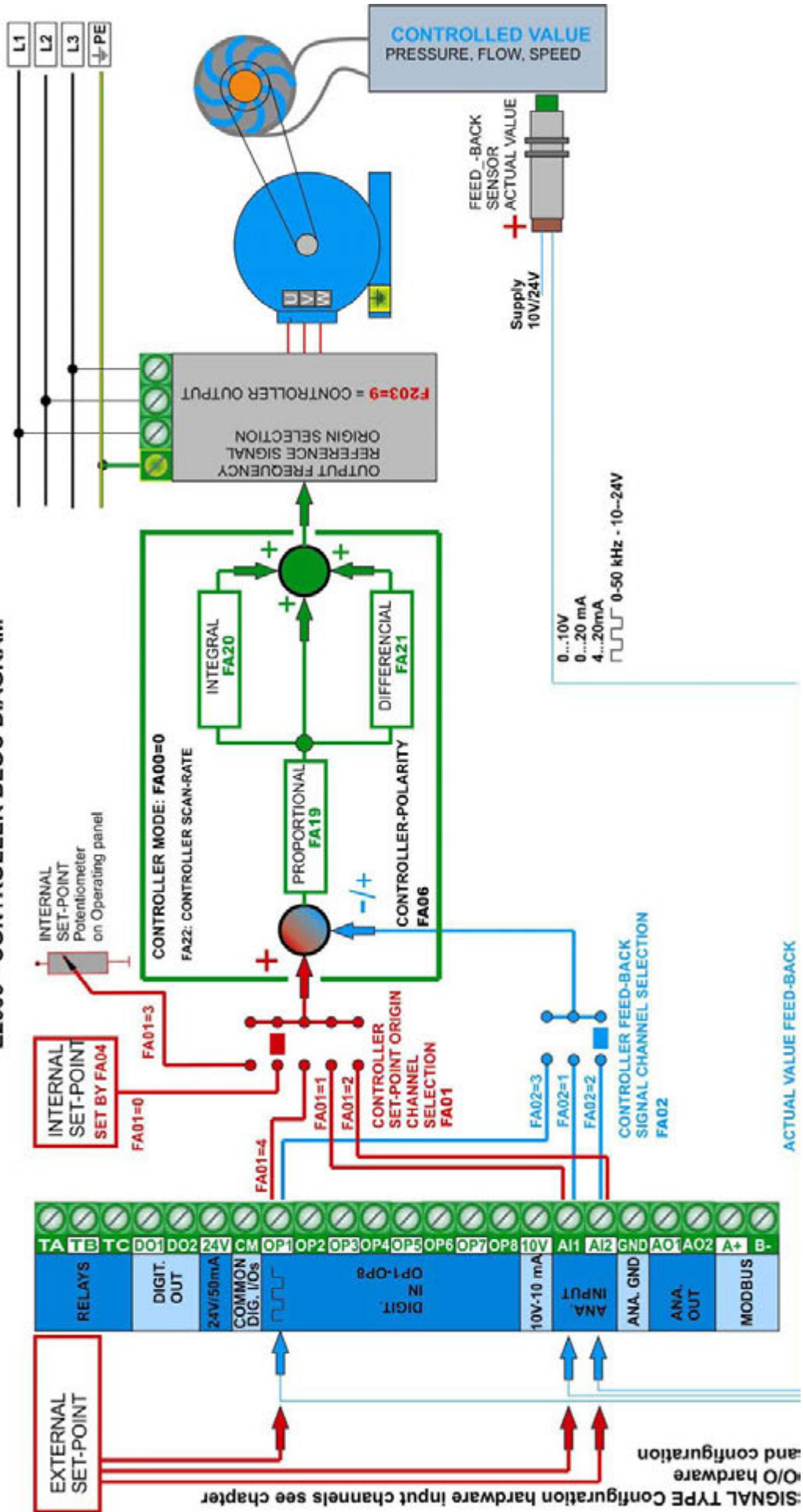

PID controller parameter setting

FA19 Proportional gain P	Range: 0.00...10.00	Default setting: 0.3
FA20 Integration time I (sec.)	Range: 0.1...100.0 sec.	Default setting: 0.3 sec.
FA21 Differential time D (sec.)	Range: 0.00...10.00	Default setting: 0.0 sec.
FA22 Controller cycle time / scan-rate (sec.)	Range: 0.1...10.0 sec.	Default setting: 0.1 sec.

Reversing lock for negative controller results

FA23 Reversing lock	Selection 0: Reversing not allowed 1: Reversing allowed	Default setting: 0
---------------------	--	--------------------

Specific pump controller parameter

Specific functions for dual pump booster station control are available in E2000+ inverters. Please ask for detailed description and configuration proposals

Master / Slave interchange

FA24 Interchange time: units	Selection: 0: hours 1: minutes	Default setting: 0
FA25 Interchange time setting (hours / min.)	1...9999	Default setting: 100 h

Idling / lack of water protection

FA26 Lack of water protection concept	Selection: 0: No protection 1: Sensor signal through digital input 2: Controller algorithm 3: Motor idling current detection	Default setting: 0
FA27 Current limit for lack of water detection (% of rated current)	Range: 10...150 %	Default setting: 80%
FA28 Recheck delay time (sec.)	Range 0.0...3000 sec.	Default: 60 sec.
FA66 Delay time for lack of water message (FA26=3)	Range: 0...60 sec.	Default setting: 2 sec.

FA26=1: Lack of water is triggered through digital input (function assignation code **30**) – it will stop the inverter and display **EP1**. The „Water OK“ signal through a different digital input (function assignation code **31**) will reset the system. FA26=1: there is no delay for fault trigger.

FA26=2: In case the controller reaches the maximum frequency, and the motor current still remains below the value in **FA27**, the controller will interpret the situation as lack of water. **EP2** will show up on the display. The inverter will stop immediately.

FA26=3: Detection via motor current measuring only. If the motor current falls below the value in **FA66**, the fault will be triggered with delay, set in **FA66**. Inverter will stop and **EP3** will show up on the display.

FA28 Recheck time, timeframe for the inverter to recheck, if lack of water condition still persists, before it restarts. It is anytime possible to reset the system, pressing.



Controller dead band +/- % of the set point

FA29 Dead band setting (% of set-point)	Range: 0.0 - 10.0 %	Default setting: 2.0
---	---------------------	----------------------

If the feed-back (actual value) stays within the dead band, the controller does not make any activity, and it keeps the output frequency constant. The FA29 parameter is used also for starting/stopping the fixed speed pump – see below

Dual pump booster control (one pump inverter controlled, one pump fixed speed)

FA30 Delay-time to start inverter pump (sec.)	Range: 2.0 - 999.9 sec.	Default setting: 20.0
FA31 Delay-time, to start fixed speed pump (sec.)	Range: 0.1 - 999.9 sec.	Default setting: 30.0
FA32 Delay-time to stop fixed speed pump (sec.)	Range: 0.1 - 999.9 sec.	Default setting: 30.0

If the feed-back value (actual value) exceeds the limits, given by FA29, the fixed pump will be started or respectively stopped. Start /Stop delay time is set by **FA31** and **FA32**.

Emergency functions

+

FA59 Selection of different emergency functions	Selection: 0: no function selected 1: FIREMODE 1 2: FIREMODE 2	Default setting: 0
FA60 Frequency for emergency condition	Range F112...F111	Default setting: 50 Hz
FA58 Pressure for emergency conditions	Range 0.0...100%	Default setting: 80%
FA62 Trigger mode	Selection: 0: no function selected 1: FIREMODE 1	

Emergency condition is triggered through specific terminal command (digital input - Dlx assignation code **33**) in this case, all protection functions are deactivated, and all auto-restart functions are activated.

FIREMODE 1 Inverter works with the regular set-point

FIREMODE 2, Inverter works with fixed frequency, set in parameter **FA60**

Emergency pressure mode is activated by terminal, digital input (Dlx assignation code **32**)

FA62=0: Inverter stays in FIREMODE, once triggered by digital input, **FA62=1:** inverter quits from FIREMODE, after trigger input is deactivated.

18) Parameter group C00: Speed / Torque control

Two different control modes are available on E2000+ inverters: **Speed-control** mode and **Torque-control** mode

FC00 Speed / Torque control mode selection	Selection: 0: Speed control 1: Torque control 2: Speed/Torque – terminal selected	Default setting: 0
---	---	--------------------

FC00=0: The output frequency is set by the speed reference value. Torque depends on the load. Torque limit can be set by parameter **FC28...FC35**

FC00=1: Torque controlled by set-point value. Speed depends on the load condition. Maximum speed can be limited by parameter **FC22...FC25**

FA00=2: A digital input signal is used, to switch over between the two control modes (function assignment code: **20**)

FC01 Delay-time for speed/torque switchover (sec.)	Range: 0,0....1,0 sec.	Default setting: 0,1 sec.
---	------------------------	---------------------------

FC02 Torque ramp-up/down time	Range: 0,1....100 sec.	Default setting: 1 sec.
--------------------------------------	------------------------	-------------------------

Torque rise/fall time 0...100%

Set-point origin for torque control

FC06 Set-point origin for torque control	Selection: 0: Internal setting FC09 1: Analogue input AI1 2: Analogue input AI2 3: Analogue input AI3 4: Pulse signal input 5: Reserved	Default setting: 0
---	--	--------------------

FC07 Torque range, referred to rated motor torque	Range: 0.0...3,000	Default setting: 3,000
FC09 Internal torque reference value (%)	Range: 0...300.0 %	Default setting: 100 %

FC07: Torque range, corresponding to 0-100% set-point signal

FC09: Internal torque set-point value

Torque boost for low frequencies (additional torque for heavy startup condition)

FC14 Torque increase signal origin	Selection: 0: Internal set FC17 1: Analogue input AI1 2: Analogue input AI2 3: Analogue input AI3 4: Pulse signal input 5: Reserved	Default setting: 0
---	--	--------------------

FC15 Torque increase in (%) motor rated torque	Range: 0.0...0,5	Default setting: 0,5
FC16 Frequency threshold for torque BOOSTS (%) f-max.	Range: 0...100 %	Default setting: 10 %
FC17 Internal setting for torque BOOST value	Range: 0..50,0%	Default setting: 10 %

FC15: 100% of torque BOOST signal correspond to the % of rated motor torque value, set in FC15

FC16: The threshold for torque boost

18) Parameter group C00: Speed / Torque control

Speed limiting for inverter, working in torque control mode:

FC22 Speed limiting set-point origin forward	Selection: 0: Set by FC23 1: Analogue input AI1 2: Analogue input AI2 3: Analogue input AI3 4: Pulse signal input 5: Reserved	Default setting: 0
FC23 Internal speed limiting value forward	Range: 0...100 %	Default setting: 10%
FC24 Speed limiting set-point origin reverse	Selection: 0: Set by FC25 1: Analogue input AI1 2: Analogue input AI2 3: Analogue input AI3	Default setting: 0
FC25 Internal speed limiting value reverse	Range: 0...100 %	Default setting: 10%

(All values are referred to f-max –F111)

Torque limiting for inverter working in speed control mode

FC28 Torque limiting signal source motor mode	Selection: 0: Set via FC30 1: Analogue input AI1 2: Analogue input AI2 3: Analogue input AI3 4: Pulse signal input 5: Reserved	Default setting: 0
FC29 Reference: 100% of limiting signal to motor rated torque	Range: 0,0....3,000	Default setting: 3,000
FC30 Internal torque limiting value motor mode (%)	Range: 0....300% %	Default setting: 200%

(All referred on motor rated torque)

FC33 Torque limiting signal source generator mode	Selection: 0: Set via FC35 1: Analogue input AI1 2: Analogue input AI2 3: Analogue input AI3 4: Pulse signal input 5: Reserved	Default setting: 0
FC34 Reference: 100% of limiting signal to motor rated torque	Range: 0,0....3,000	Default setting: 3,000
FC35 Internal torque limiting value generator mode (%)	Range: 0....300% %	Default setting: 200%

(All referred on motor rated torque)

+

Torque / Current limit for field wakening area

FC 48 Activation of secondary limiting	Selection: 0: Limiting fixed 1: Depending on frequency threshold	Default setting: 0
FC49 Sekundary torque/current limit (%)	Range: 50...200 %	Default setting: 120%
FC50 Start transition frequency (Hz)	Range: 1.0 Hz...FC51	Default setting: 15 Hz
FC51 End transition frequency (Hz)	Range: FC50...F111 Hz	Default setting: 30 Hz

In V/Hz mode: To limit motor current in the field wakening area

In SLV mode: To limit torque in the field wakening area

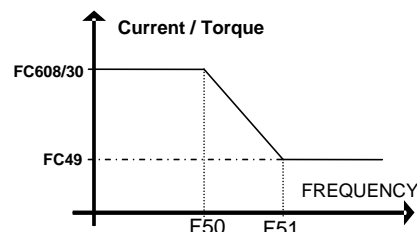

19) E2000+ Diagnosis

Intelligent diagnosis tools for set-up and troubleshooting.



Digital inputs: Status monitoring

<p>F330 Digital input monitor</p>	<p>The single vertical segments on the 7 segment display correspond to the DI1...DI8 input status, starting from left side for DI1. Segments flip down for activated inputs</p>
--	---



Analogue input value check

<p>F331 Analogue value on AI1</p>	<p>0...4096 = 0...100%</p>
<p>F332 Analogue value on AI2</p>	<p>0...4096 = 0...100%</p>
<p>F333 Analogue value on AI3</p>	<p>0...4096 = 0...100%</p>

Digital output stimulation

<p>F335 Relais output stimulation</p>	<p>Digital outputs are switched ON/OFF, using keys  </p>
<p>F336 Digital output DO1 stimulation</p>	
<p>F337 Digital output DO2 stimulation</p>	

Analogue output stimulation

<p>F338 Stimulation of analogue output AO1</p>	<p>The analogue output signal can be set from 0...100% (0...4096), using   keys</p>
<p>F339 Stimulation of analogue output AO2</p>	

EURA Drives GmbH

Mühlenweg 143
22844 Norderstedt (Germany)

Tel.: +49 40 589 7950 0
Fax.: +49 40 589 7950 29

www.euradrives.eu